

Operating Instructions

Barrier MHTM™ MicroDrive



MAGNETIC Automation Corporation
3160 Murrell Road
Rockledge, Florida, 32955
USA

Tel.: +1 321 635 8585
Fax.: +1 321 635 9449
E-Mail: info@ac-magnetic.com
Internet: www.ac-magnetic.com

Important Safety Instructions



- Read and follow all instructions.
- Never let children operate or play with barrier controls. Keep the remote control (where provided) away from children.
- Personnel should keep away from a barrier arm in motion and keep the moving barrier arm in sight until it is completely closed or opened. No one should cross the path of a moving barrier arm.
- Test the barrier system monthly. After adjusting the force or the limit of travel, retest the barrier system. Failure to adjust and retest the barrier system properly can increase the risk of injury or death.
- Keep barrier properly maintained. Read the owner's manual. Have a qualified service person make repairs to barrier hardware.
- The barrier is for vehicles only. Pedestrians must use separate entrance.
- Save these instructions.



Contents

1	General	11
1.1	Information regarding the operating instructions	11
1.2	Pictogram explanation	12
1.3	Limitation of liability.....	13
1.4	Copyright protection.....	13
1.5	Scope of delivery	14
1.6	Warranty	14
1.7	Customer service.....	14
1.8	UL-Declaration	14
1.9	Environmental protection	15
2	Safety	16
2.1	Intended use of the barriers.....	16
2.1.1	Intended use for certain road vehicles	16
2.1.2	Non-Intended use.....	17
2.2	Operator's responsibility	18
2.3	Changes and modifications	18
2.4	Specialists and operating personnel.....	19
2.4.1	Requirements	19
2.5	Personal protective equipment.....	20
2.6	Occupational safety and special dangers.....	20
2.6.1	Danger symbols on the MHTM™ MicroDrive barrier.....	20
2.6.2	Hazard notes and occupational safety	21
2.7	Danger area.....	28
3	Identification	29
3.1	Type plate	29
3.2	Type code	30
4	Technical data	31
4.1	Access	31
4.1.1	Dimensions and weight	31
4.1.2	Electrical connection	32
4.1.3	Operating conditions	32
4.1.4	Operating times	33
4.2	Access Pro H	34
4.2.1	Dimensions and weight	34
4.2.2	Electrical connection	35
4.2.3	Operating conditions	35
4.2.4	Operating times	36

Contents

4.3	Parking	37
4.3.1	Dimensions and weight	37
4.3.2	Electrical connection.....	38
4.3.3	Operating conditions.....	38
4.3.4	Operating times	38
4.4	Toll.....	39
4.4.1	Dimensions and weight	39
4.4.2	Electrical connection.....	40
4.4.3	Operating conditions.....	40
4.4.4	Operating time	40
4.5	Control unit.....	41
4.6	Plug-in module "Detector A–B"	42
4.7	Plug-in module "Radio"	42
5	Design and function.....	43
5.1	Design	43
5.1.1	Access and Parking.....	43
5.1.2	Access Pro H.....	44
5.1.3	Toll	45
5.2	Function	46
6	Transport and storage	47
6.1	Safety	47
6.2	Transport inspection.....	48
6.3	Transport.....	49
6.4	Storage.....	49
7	Design notes for induction loops	50
8	Assembly and installation	53
8.1	Safety	53
8.2	Required steps	55
8.3	Foundation and empty conduits.....	56
8.3.1	Foundation and empty conduits for the barrier	57
8.3.2	Foundation and empty conduits for light barrier post.....	59
8.4	Assembly and installation of induction loops	61
8.4.1	Directions for the assembly and installation of induction loops.....	61
8.4.2	Induction loops.....	63
8.4.3	Testing induction loops	63
8.4.4	Installing induction loops in bitumen, asphalt, or concrete	63
8.4.5	Installing induction loops under interlocking stone paving	65
8.5	Unpacking	66

8.6	Assemble housing	66
8.7	Assemble light barrier post	68
8.8	Assemble safety light barrier	69
8.8.1	Assemble transmitter.....	69
8.8.2	Assemble receiver.....	70
8.9	Assemble barrier arm type "VarioBoom"	71
8.10	Assemble edge protection	71
8.11	Assembling flange and barrier arm.....	72
8.11.1	Type "VarioBoom" and "MicroBoom"	72
8.11.2	Barrier arm type "MicroBoom-T"	75
8.12	Conversion "left version" – "right version" (VarioBoom and MicroBoom)	78
8.13	Check and set the balancing springs in the lever system.....	81
8.13.1	Setting balancing springs	82
8.13.2	Overview table balancing springs	84
8.14	Align barrier housing and light barrier post.....	86
8.15	Installing warning signs.....	87
8.16	Check assembly and installation	87
9	Electrical connection	88
9.1	Safety.....	88
9.2	Installing electrical protective devices	91
9.3	Connecting the mains supply.....	91
9.4	Connect customer's control lines (signalling devices).....	93
9.4.1	Connecting safety devices	94
9.4.2	Plausibility check of the safety devices	95
9.4.3	Connecting safety loop.....	96
9.4.4	Connect and test the safety light barriers.....	97
9.4.5	Connecting emergency opening contacts	98
9.4.6	Digital inputs.....	98
9.4.7	Digital outputs and output relays	101
9.5	Checking the electrical connection	105
10	Parameterising control unit	106
10.1	Safety	106
10.2	Control elements control unit.....	106
10.3	Displays on the control unit.....	107
10.4	Symbols in the display	108
10.4.1	Control button functions	108
10.4.2	Current state of the barrier	109
10.4.3	Current program mode	110
10.4.4	Current state of the induction loops	110
10.4.5	Further symbols.....	110

Contents

10.5	Parameterising options	111
10.6	Parameterising values.....	112
10.7	Select program mode.....	113
10.7.1	Mode 1: Maintained contact	114
10.7.2	Mode 2: Deadman	115
10.7.3	Mode 3: Pulse control (bistable).....	116
10.7.4	Mode 4: Two-Pulse control (bistable).....	117
10.7.5	Automatic modes 5 to 8: Drive direction 1 – overview and differences.....	118
10.7.6	Automatic Modes 5 to 8: Drive direction 2.....	122
10.7.7	Mode "Service"	123
10.8	Menu "Information" (i).....	124
10.9	Program mode	124
10.10	Menu "Setup"	125
10.10.1	Barrier speed	125
10.10.2	Delays.....	125
10.10.3	Cut off angle	127
10.10.4	Inputs	127
10.10.5	Outputs	127
10.10.6	Vend count.....	128
10.10.7	Impact settings.....	131
10.10.8	Start-up behaviour	132
10.10.9	Power failure.....	137
10.10.10	Closure by light barrier	138
10.10.11	Master/Slave.....	138
10.11	Menu "Attachments".....	139
10.11.1	Signal light.....	139
10.11.2	Boom contact settings	142
10.11.3	Boom locking	143
10.12	Menu "Service".....	143
10.13	Menu "Information".....	144
10.14	Menu "Motor GW (Gateway).....	144
10.15	Menu "Detector 1 (A-B)".....	145
10.15.1	Check the working frequency of the induction loops.....	146
10.15.2	Reconciling and setting the operating frequency of the induction loop.....	147
10.16	Menu "Detector 2 (C-D)"	149
10.17	Menu "Radio control"	149
10.18	Factory Settings	153

11	Start-up and operation	154
11.1	Safety	154
11.2	Commissioning	155
11.3	Switching on and off the barrier	155
11.4	Putting the barrier temporarily out of operation	157
12	Maintenance	158
12.1	Safety	158
12.2	Cleaning	159
12.3	Maintenance schedule	160
13	Malfunctions	162
13.1	Safety	162
13.2	Malfunction table – barrier malfunctions	163
13.3	Warning and interference messages on the display ..	166
13.3.1	Warning and interference messages – Logic control (Control unit)	166
13.3.2	Warning and interference messages – Motor GW	168
13.3.3	Warning and interference messages - Detector	169
13.3.4	Warning and interference messages – All modules	170
13.4	Reset the barrier	170
13.5	Closing or opening the barrier arm in case of power failure	171
14	Repair	172
14.1	Safety	172
14.2	Spare parts	173
14.3	Replacing the barrier arm	173
14.3.1	Barrier arm type "VarioBoom" and "MicroBoom"	173
14.3.2	Barrier arm type "MicroBoom-T"	177
15	Decommissioning, disassembly and disposal	178
16	UL-Declaration.....	179
17	Grant of equipment authorization – Radio receiver module	181
18	Appendix.....	183
18.1	Wiring diagrams	183
18.2	Menu setup	191
	Index.....	195



1 General

1.1 Information regarding the operating instructions

These operating instructions provide crucial information on handling of MAGNETIC barriers MHTM™ MicroDrive. Pre-requisite for safe working is the observance of all specified safety notes and instructions.

In addition, the local accident prevention regulations valid at the barrier's area of application and general safety regulations have to be complied with.

Carefully read the operating instructions before starting any work! They are a product component and must be kept in direct proximity of the barrier, well accessible to the personnel at all times.

When passing the barrier on to third parties, the operating instructions must also be handed over.

Components from other suppliers may have their own safety regulations and instructions for use. These must also be observed.

Program versions Control unit MGC and plug modules

These operating instructions are only valid as of the following program versions. Software number (software #) and software version (SW version) are displayed in the menu "Module info".

Designation	Software #	SW version
Master Controller Standard	4915,1000	0.9
Motor Gateway Controller	4915,3000	0.6
Detector module 2-channel	4915,3001	0.6
Radio module 433 MHz	4915,3003	0.6
Ethernet Module	4915,3004	0.1

Table 1: Program versions

General

1.2 Pictogram explanation

Warning notes

Warning notes are characterised by pictograms in these operating instructions. The warning notes are followed by signal words expressing the scale of the hazard.

It is absolutely essential to observe the notes and to proceed with caution in order to prevent accidents as well as bodily injuries and property damage.

⚠ DANGER!	
	<p>DANGER!</p> <p>... points to an immediately dangerous situation, which leads to death or severe injuries if it is not avoided.</p>

⚠ WARNING!	
	<p>WARNING!</p> <p>...points to a possibly dangerous situation that may lead to death or severe injuries if it is not avoided.</p>

⚠ CAUTION!	
	<p>CAUTION!</p> <p>... points to a potentially dangerous situation, which can lead to minor injuries if it is not avoided.</p>

NOTICE!	
	<p>NOTICE!</p> <p>... points to a potentially harmful situation, which can lead to property damage if it is not avoided.</p>

Hints and recommendations

	<p>NOTE!</p> <p>...highlights useful hints and recommendations as well as information for an efficient and trouble-free operation.</p>
---	---

1.3 Limitation of liability

All specifications and notes in these operating instructions were compiled with consideration to the valid standards and regulations, the state of the art as well as to our long-standing knowledge and experience.

The manufacturer is not liable for damages caused by:

- Non-observance of the operating instructions
- Improper use
- Deployment of non-trained personnel
- Arbitrary modifications
- Technical changes
- Use of non-approved spare and wear parts.

The actual scope of supply may differ from the explanations and illustrations described in this manual in case of special designs, if additional order options are made use of, or due to latest technical changes.

Incidentally, the responsibilities agreed upon in the delivery contract, the general terms and conditions as well as the manufacturer's conditions of delivery and the statutory provisions valid at the time of contract conclusion shall apply.

In no event shall MAGNETIC be liable for any incidental, indirect, special or consequential damages in connection with the use of the product.

1.4 Copyright protection

MAGNETIC retains sole and exclusive ownership of all intellectual property rights with respect to the products.

Surrendering the operating instructions to third parties without written permission of the manufacturer is not permitted.



NOTE!

Content details, texts, drawings, pictures and other illustrations are protected by copyright and are subject to industrial property rights. Any improper use shall be liable to prosecution.

Any type and form of duplication – also of extracts – as well as the exploitation and/or communication of the contents are not permitted without the manufacturer's written declaration of consent.

General

1.5 Scope of delivery

The scope of delivery comprises:

- 1 barrier housing
incl. drive unit and control
- 1 Barrier
- 2 Mounting profiles
- 2 Warning signs
- Edge protection
- Options if applicable

Supplied documentation per barrier:

- These operating instructions.

1.6 Warranty

Subject to the condition that the operating instructions are observed, and that no inadmissible operations are carried out on the technical equipment, and that the installation has suffered no mechanical damage, MAGNETIC grants a warranty on all mechanical and electrical components of the product to the extent as stated in its standard terms of sales and delivery or as contractually agreed in writing.

MAGNETIC makes no warranties, express or implied, regarding the products, including the value, design, condition, merchantability or fitness for particular purpose or use of the products.

1.7 Customer service

Your vendor is available to you for technical information

For the address, see invoice, delivery note or the reverse of these instructions.



NOTE!

In order to enable fast handling note the data of the type plate such as type, serial number, version etc. before calling.

1.8 UL-Declaration

UL-Declaration refer to page 179.

1.9 Environmental protection

NOTICE!

**NOTICE!****Danger for the environment by improper disposal of components or the barrier!**

In case of improper disposal of components or the barrier, damage to the environment may result.

Therefore:

- Observe the valid environmental directives.
- After appropriate disassembly the parts have to be recycled.
- Separate recyclable fraction and feed to recycling.

2 Safety

2.1 Intended use of the barriers

The MAGNETIC MHTM™ MicroDrive barrier is intended for installation only on passageway used for vehicles. Pedestrians must be supplied with a separate access opening. The pedestrian access opening shall be designed to promote pedestrian usage. Locate the barrier such that persons will not come in contact with the vehicular passageway during the entire path of travel of the vehicular barrier.

The barrier is either controlled by a person in manual operating modes or by access control systems in automatic operating modes and monitored by induction loops and/or safety light barriers.

Electrical energy is used exclusively for operating the barrier. The barrier arm weight is balanced out by spring energy.

The barrier consists of the barrier housing with drive system and control, as well as the barrier arm.

2.1.1 Intended use for certain road vehicles

Certain road vehicles according to chapter 2.1 paragraph 1 need to have sufficiently large metal areas in the vehicle floor area to enable detection by induction loops.

Other or complementary safety facilities must be provided for road vehicles that cannot be detected by induction loops due to the metal area in the vehicle floor area being too small.

2.1.2 Non-Intended use

Control of pedestrian traffic as contrary to intended use.



The barriers must not be used at railway crossings.

The barriers are not approved for pedestrian traffic, bicycles or animals.

The barriers must not be used in explosive environments.

All uses not described as intended use are prohibited.

No accessories must be connected or installed if they are not specified expressly according to quantity and characteristics and approved by Magnetic Autocontrol.

 WARNING!	
	<p>WARNING! Non-intended use is dangerous!</p> <p>Every non-intended use can lead to dangerous situations.</p> <p>Therefore:</p> <ul style="list-style-type: none">– Only use barrier as intended.– All specifications in these operating instructions have to be strictly complied with.

Any types of claims due to damage arising from improper use are excluded. The operator alone shall be responsible for any damage arising from improper use.

2.2 Operator's responsibility

The operator must comply with the statutory obligations regarding work safety.

In addition to the work safety notes in these operating instructions, the safety, accident prevention and environmental provisions applicable for the area the barrier is used in must be complied with.

In particular, the operator must:

- gather information on applicable work protection provisions.
- determine additional dangers in a risk assessment.
- implement the required method of operation of the barrier on site from the operating instructions.
- regularly verify throughout the barrier's time of use that the operating instructions drawn up by him comply with the current state of the regulations.
- adapt the operating instructions to any new provisions, standards and usage conditions - where required.
- clearly determine the responsibilities for installation, operation, maintenance and cleaning of the barrier.
- ensure that all employees that are working at or with the barrier have read and understood the operating instructions.
- Furthermore, the operator must train personnel regarding the use of the barrier at regular intervals and provide information on possible danger.

Furthermore, the operator is responsible for:

- keeping the barrier in perfect technical order and condition at all times.
- maintaining the barrier according to the maintenance intervals and performing the safety inspections as stipulated.
- checking all protective facilities for completeness and proper function at regular intervals.

The operator is also responsible that the danger area of the barrier arm cannot be accessed by any unauthorised, and in particular not by children, under any circumstances.



2.3 Changes and modifications

Changes, modifications and re-builds of the barrier or installation can cause unforeseen danger.

A written authorisation of the manufacturer is required before executing any technical changes and extensions on the barrier.

2.4 Specialists and operating personnel

2.4.1 Requirements

 WARNING!	
	<p>WARNING! Risk of injury in case of inadequate qualification!</p> <p>Improper handling can lead to considerable bodily injuries and property damage.</p> <p>Therefore:</p> <ul style="list-style-type: none"> – Have any activities only carried out by the individuals designated for that purpose.

The operating instructions specify the following qualification requirements for the different fields of activity:

- **Instructed people**
 have been instructed during instructions provided by the operator with regard to the work assigned to them and possible hazards arising from improper conduct.
- **Specialised staff**
 are able, due their technical training, knowledge and experience as well as their knowledge of the pertinent regulations able to carry out the work assigned to it and to independently recognize potential hazards.
- **Electrical specialists**
 are able, due to their technical training, knowledge and experiences as well as knowledge of the relevant standards and regulations, to execute tasks on electrical systems and to independently recognize possible hazards.
 In Germany, the electrical specialist must comply with the provisions of accident prevention regulation BGV A3 (e.g. master electrical fitter). Appropriate regulations apply in other countries. The regulations valid there must be observed.
 The installation is to be made by a professional installer according to NFPA 70 National Electrical Code and Local Code.
- **MHTM™ MicroDrive service experts**
 comply with the requirements of the electricians named here. Additionally, these electricians are trained and authorised by MAGNETIC to perform special repair and service work on MHTM™ MicroDrive barriers.

It must be expected that only those people are deployed who carry out their work reliably. People, whose ability to respond is affected, e.g. by drugs, alcohol or medicines, must not be used. Furthermore, the age and profession-specific regulations valid at the operating location must be observed when selecting personnel.

2.5 Personal protective equipment

It is necessary to wear personal protective equipment when dealing with the barrier so as to minimise health hazards.

Before carrying out any work, properly dress in the necessary protective equipment such as work clothes, protective gloves, safety shoes, helmet and wear during work.

2.6 Occupational safety and special dangers

The remaining risks resulting from the risk analysis are specified in the following section.

Observe the safety notes listed here and the warning notes mentioned in the other chapters of these instructions to reduce health hazards and to avoid dangerous situations.

2.6.1 Danger symbols on the MHTM™ MicroDrive barrier

The relevant dangerous areas on the barriers can be identified by the following pictograms:

Electric voltage

⚠ DANGER!	
	<p>DANGER! Mortal danger by electric voltage!</p> <p>... indicates life threatening situations caused by electric voltage. Non-observance of the safety instructions causes severe injuries or death. Necessary work may only be carried out by an electrical specialist.</p> <p>This pictogram is fixed on the following component:</p> <ul style="list-style-type: none"> – Assembly plate in the barrier housing.

⚠ WARNING!	
	<p>WARNING! Danger of crushing!</p> <p>... indicates the presence of components and items moving towards each other. Non-observance of the safety instructions can lead to severe injuries.</p> <p>This pictogram is fixed on the following component:</p> <ul style="list-style-type: none"> – At the access points for the lever system on the front and rear of the top assembly plate. – At the access point for the flanged shaft on the front and rear of the top assembly plate.

Hot surfaces

⚠ CAUTION!	
	<p>CAUTION! Danger of burns!</p> <p>... indicates the presence of a hot surface. Non-observance of the safety instructions can lead to minor injuries.</p> <p>This pictogram is fixed on the following component:</p> <ul style="list-style-type: none"> – Motor in the barrier housing. – Heating (optional) in the barrier housing.

2.6.2 Hazard notes and occupational safety

For your own safety and for the protection of the barrier modules, the following information must be observed and complied with:

Electric voltage

⚠ DANGER!	
	<p>DANGER! Mortal danger by electric voltage!</p> <p>Touching live parts can be lethal.</p> <p>Damage to the insulation or to individual components can be lethal.</p> <p>Therefore:</p> <ul style="list-style-type: none"> – Switch off the power supply immediately in case of damage to the insulation and arrange repair. – Only electrical specialists may carry out work on the electrical system. – Switch off power supply and secure against re-activation before performing any work. Test for absence of voltage! – Never bypass or deactivate fuses. – When replacing fuses observe the correct amperage specification. – Keep moisture and dust away from live parts. Moisture or dust may cause a short circuit. If the electrical connection is established during precipitation, e.g. rain or snow, penetration of moisture must be prevented by suitable measures, such as a protective cover.

Safety

Electric voltage – missing protective facilities

⚠ DANGER!	
	<p>DANGER! Mortal danger by electric voltage!</p> <p>The safety installations that are required according to regional and local regulations must be provided by the customer. Usually these are:</p> <ul style="list-style-type: none"> – Ground fault circuit interrupter (GFCI) – Circuit-breaker – Appropriate listed 2-pole main switch.

Thunderstorm, lightning, electric voltage

⚠ DANGER!	
	<p>DANGER! Mortal danger from lightning and electrical voltage!</p> <p>If lightning strikes the barrier, contact to the barrier components and direct proximity to the barrier includes mortal danger.</p> <p>Therefore:</p> <ul style="list-style-type: none"> – Never install the barrier housing and barrier arm during thunderstorms. – Protect yourself in buildings or vehicles.

Improper operation**⚠ WARNING!****WARNING!****Danger from improper operation of the barrier!**



Improper operation of the barrier can cause severe or lethal injuries!

Therefore:



- The barrier closes automatically in certain program modes. Passing of two vehicles within a single opening process must be prevented by the construction and appropriate signs or signals.
- The barrier is intended for a single drive direction at the same time. The operator must prevent concurrent oncoming traffic by suitable measures, such as signs.
- Only additions to the barrier casing or boom that are permitted by the manufacturer may be installed.
- Keep barrier area free from objects.
- Do not use the barrier arm as a lifting device.
- Never climb over or crawl under boom.
- Never sit on the barrier housing or climb over it.
- Do not sit or have yourself lifted by the boom.
- Never open or stop the boom manually.

Safety

Entering the danger area of the barrier

 WARNING!	
	<p>WARNING! Danger from entering the danger area!</p> <p>The MAGNETIC MHTM™ MicroDrive barriers are intended exclusively for closing off passages for motor vehicles and trucks. For vehicles that cannot be detected by induction loops, additional safety measures must be provided. Entering the danger area can cause severe or lethal injuries.</p> <p>Therefore, the operator must take the following measures:</p> <ul style="list-style-type: none"> – Observing country-specific laws and regulations. – Presence of persons and animals must be excluded. – Marking the danger area by prohibition signs for persons, bicyclers, etc. – If required, set up barriers such as fences and railings. – If required, set up separate passageway for persons and bicycles.

Closing boom

 WARNING!	
	<p>WARNING! Danger from closing boom!</p> <p>A closing boom may cause severe or lethal injury to persons, bicycler and cabriolet drivers!</p> <p>Therefore:</p> <ul style="list-style-type: none"> – Install safety installations, such as a MAGNETIC safety light barrier as surveillance device. The surveillance device must prevent the closing of the barrier in case a person or a vehicle is standing below the barrier. – Only use barrier arms approved of by MAGNETIC. – Assemble edge protection. – If the edge protection was damaged it must be replaced immediately or the barrier must be taken out of operation.

Improper transport

⚠ WARNING!	
	<p>WARNING! Danger from improper transport of the barrier arm and housing!</p> <p>The weight of the barrier arm or housing can severely injure a person!</p> <p>Therefore:</p> <ul style="list-style-type: none"> – Have them transported by specialists only. – Use lifting gear or forklift with a suitable pallet. – Use suitable lifting gear (loops, etc.) for lifting the barrier arm and barrier housing. The lifting gear must be designed for the respective weights. – Carrying and lifting the barrier arm and housing from the pallet should be done by at least two people.

Heavy weight



⚠ WARNING!	
	<p>WARNING! Risk of injury when lifting heavy objects alone!</p> <p>The weight of heavy objects can severely injure a person!</p> <p>Therefore:</p> <ul style="list-style-type: none"> – Lifting and carrying the barrier arm and housing from the pallet should be done by a minimum of two people.

Falling components



⚠ WARNING!	
	<p>WARNING! Risk of injury from falling components!</p> <p>Falling components such as the barrier arm can cause severe injury!</p> <p>Therefore:</p> <ul style="list-style-type: none"> – Only place the barrier arm horizontally. – Only install the barrier arm when there is no or little wind. – Secure the barrier housing against tilting before assembly. – Install the barrier housing correctly.

Safety



Insufficient fixing

 WARNING!	
	<p>WARNING! Risk of injury at insufficient fixing!</p> <p>Insufficient fixing of individual components such as barrier housing, barrier arm and additions permitted by the manufacturer can cause severe injury!</p> <p>Therefore:</p> <ul style="list-style-type: none"> – Only qualified and skilled personnel are allowed to assemble the barrier and the appropriate components. – Check the foundation anchors fit tightly before starting the barrier. – Check the firm fixing of all screws according to maintenance schedule.

Danger of crushing, lever system and flange shaft

 WARNING!	
	<p>WARNING! Danger of crushing at opened barrier housing at the lever system and flange shaft!</p> <p>The lever system and the flange shaft in the barrier housing can cause serious crushing injuries!</p> <p>Therefore:</p> <ul style="list-style-type: none"> – Only skilled personnel are allowed work on the barrier housing and barrier arm. – Only work at the barrier housing when the power supply is turned off. – Assemble barrier housing without barrier arm. – For assembly of the barrier arm, strictly observe the descriptions in chapter 8.7. – Wear protective gloves if necessary.

Danger of crushing, barrier arm and flange

 WARNING!	
	<p>WARNING! Danger of crushing between barrier arm and barrier housing!</p> <p>Moving parts may cause serious crushing injuries!</p> <p>Therefore:</p> <ul style="list-style-type: none"> – Only skilled personnel are allowed work on the barrier housing and barrier arm. – Only work at the barrier housing when the power supply is turned off



Illegible signage

⚠ CAUTION!	
	<p>CAUTION! Risk of injury by illegible symbols!</p> <p>Labels and signs can become dirty or unrecognisable in the course of time.</p> <p>Therefore:</p> <ul style="list-style-type: none">– Always keep safety, warning and operating notes in a well readable condition.– Immediately renew damaged or unrecognisable signs or labels.

Safety

2.7 Danger area

Danger of crushing and shearing, barrier arm

 WARNING!	
	<p>WARNING! Danger of crushing and shearing when the barrier opens or closes!</p> <p>When a barrier opens or closes, the barrier arm may lead to severe crushing or injury!</p> <p>Therefore:</p> <ul style="list-style-type: none"> – Keep a distance of at least 2 ft (610 mm) between the barrier arm and other objects, such as walls, masonry or houses. – Install the barrier system only when all exposed pinch points are eliminated or guarded.

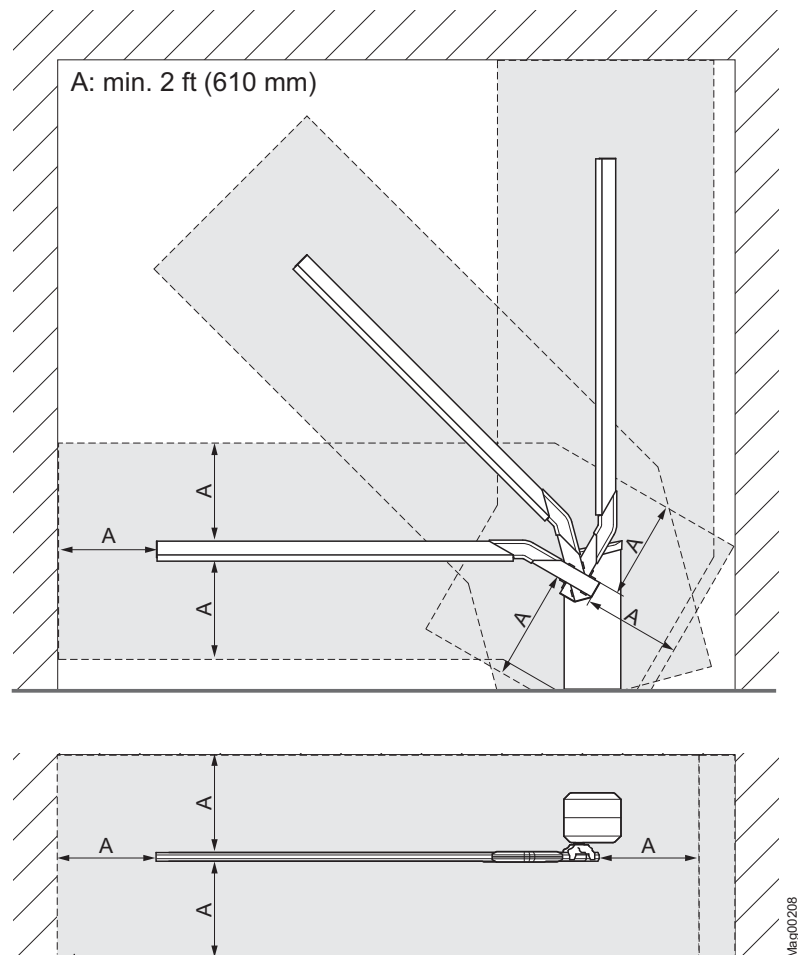

Fig. 1: Danger area

A Danger area of at least 2 ft (610 mm)

3 Identification

3.1 Type plate

The type plate is provided inside at the barrier housing, next to the hood attachment.

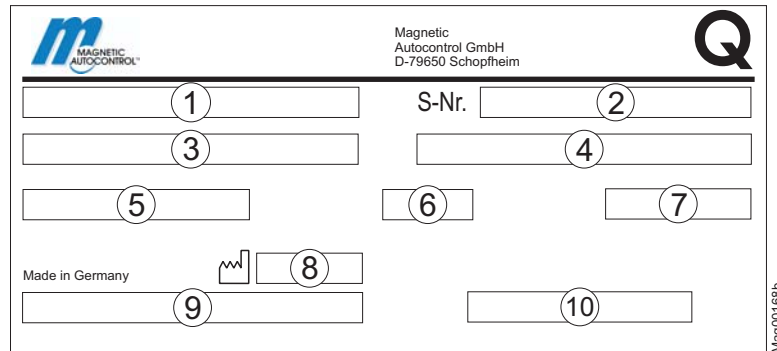

The diagram shows a rectangular type plate with the following layout:

- Top left: Magnetic Autocontrol logo.
- Top center: "Magnetic Autocontrol GmbH D-79650 Schopfheim".
- Top right: A large letter "Q" in a circle.
- Field 1: A rectangular box.
- Field 2: A rectangular box labeled "S-Nr.".
- Field 3: A rectangular box.
- Field 4: A rectangular box.
- Field 5: A rectangular box.
- Field 6: A small rectangular box.
- Field 7: A rectangular box.
- Field 8: A rectangular box containing a waveform icon and the text "Made in Germany".
- Field 9: A rectangular box.
- Field 10: A rectangular box.

Mag00168b

Fig. 2: Type plate

- 1 Type code
- 2 Serial number
- 3 Power supply, Frequency
- 4 Nominal current consumption (max. peak current consumption) + additional current consumption when using the service socket
- 5 Operating time (Opening time/closing time)
- 6 Protection class
- 7 Duty cycle
- 8 Manufacturing year and month
- 9 Bar code for type code
- 10 Bar code for serial number

Identification

3.2 Type code

													-	R	A	0	3	0	0	0
1	2	3	4	5	6	7	8	9	10	11	12	13	14	15	16	17	18	19	20	

Position	Description
1 – 12	Product group: ACCESS Magnetic.Access ACCESS-L Magnetic.Access lang ACCESS PRO Magnetic.Access Pro ACCESS PRO-L Magnetic.Access Pro lang ACCESS PRO-H Magnetic.Access Pro hoch ACCESS SEL Magnetic.Access Select ACCESS SEL-L Magnetic.Access Select lang PARKING Magnetic.Parking PARING PRO Magnetic.Parking Pro PARKING SEL Magnetic.Parking Select TOLL Magnetic.Toll TOLL PRO Magnetic.Toll Pro
13	-
14	L = Left version R = Right version
15	A = Standard wide range 85 – 264 V AC / 47 – 63 Hz C = UL-version (US market)
16 – 18	Line width Standard length: 010 = 10 feet 012 = 12 feet 015 = 15 feet 020 = 20 feet
19	Colours 0 = Top cover: IGP-DuraFace 581MA20000A00 (RAL 2000) Housing: IGP-DuraFace 622SA22770A00 (RAL2000) Doors: IGP-DuraFace 5803E71319A10 (anthracite) 1 = Top cover: IGP-DuraFace 581ME71384A10 (grey aluminium) Housing: IGP-DuraFace 622SE71384A10 (grey aluminium) Doors: IGP-DuraFace 5803E71319A10 (anthracite) 2 = Top cover: IGP-DuraFace 581ME90060A10 (white aluminium) Housing: IGP-DuraFace 622SE90060A10 (white aluminium) Doors: IGP-DuraFace 5803E71319A10 (anthracite) 4 = Top cover: IGP-DuraFace 6825A90100A10 (white aluminium) Housing: IGP-DuraFace 6825A90100A10 (white aluminium) Doors: IGP-DuraFace 5803E71319A10 (anthracite)
20	0

4 Technical data

4.1 Access

4.1.1 Dimensions and weight

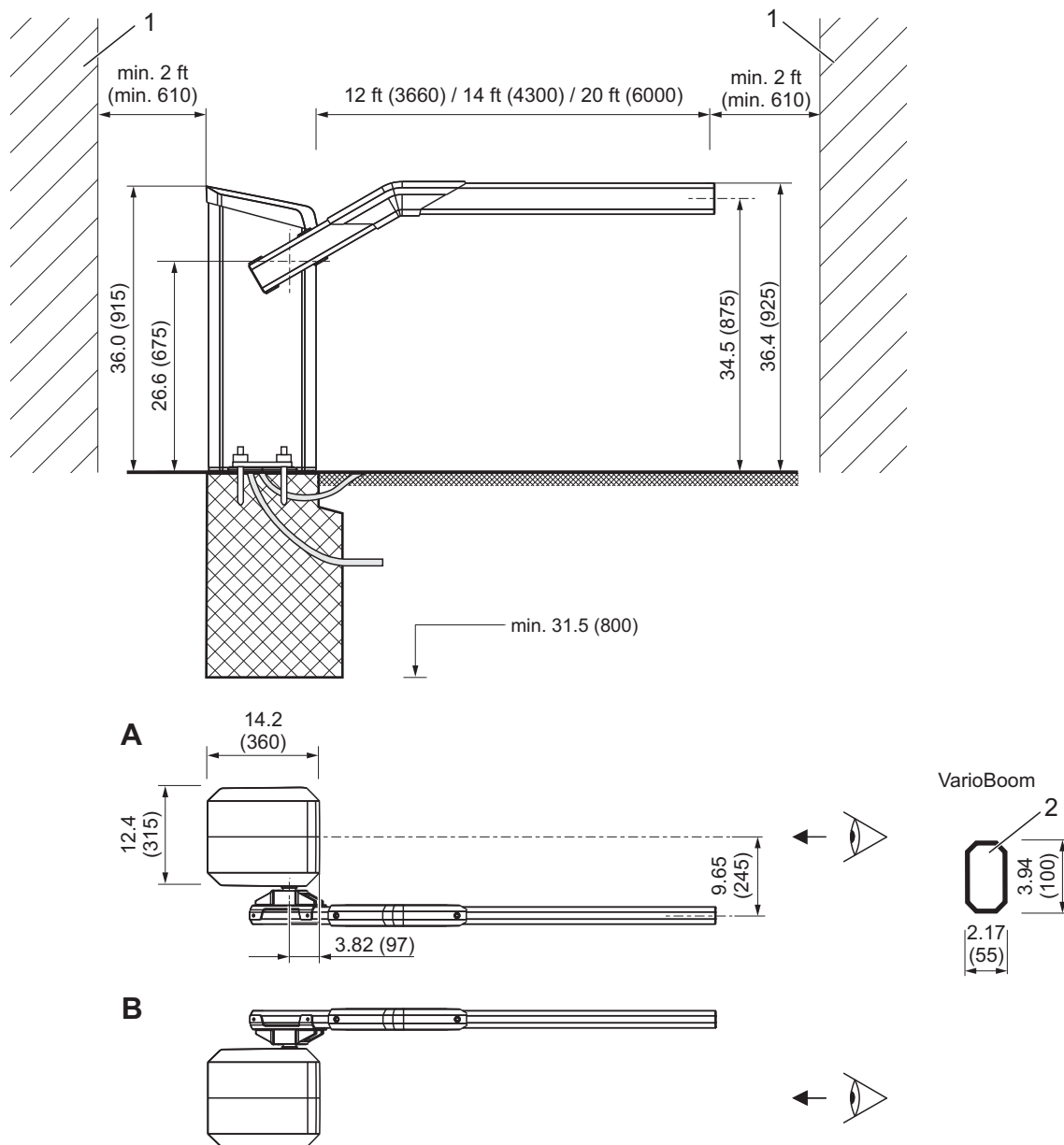

Fig. 3: Dimensions barrier system and barrier arm profile – "Access" series
 Dimensions in inch or feet are without parenthesis. Dimensions in mm are in parenthesis.

- 1 Object such as wall, building. etc. → See also page 28, chapter 2.7.
- 2 VarioBoom (barrier arm) with octagon boom profile

- A Barrier. left version
- B Barrier. right version

Technical data

Designation	Unit	Access		Access Pro		Access Select	
			L		L		L
Line width	ft (m)	12 (3.66)	15 (4.57)	12 (3.66)	20 (6.10)	12 (3.66)	20 (6.10)
Barrier housing (width x depth x height)	in (mm)	→ See page 31, Fig. 3. 12.4 x 13.6 x 36.0 (315 x 360 x 915)					
Weight barrier housing	lbs (kg)	88.2 (40)					

Table 2: Dimensions and weight – "Access" series

4.1.2 Electrical connection

Designation	Unit	Access		Access Pro		Access Select	
			L		L		L
Supply voltage	V AC	85 to 264					
Frequency	Hz	50 / 60					
Nominal current consumption ¹⁾	A	0.5	1.0	1.5	0.5	1.5	0.5
Max. peak current consumption ²⁾	A	2.5	2.5	3.5	3.0	3.5	3.0
Nominal power consumption ¹⁾	W	25	50	95	25	95	25
Duty cycle	%	100					

1) The values refer to a power supply of 120 V AC / 60 Hz and without accessories.

2) The values refer to a power supply of 120 V AC / 60 Hz, with illumination, service socket not used. Using the service socket in the barrier housing increases the current consumption by 5 A.

Table 3: Electrical connection – "Access" series

4.1.3 Operating conditions

Designation	Unit	Access		Access Pro		Access Select	
			L		L		L
Ambient temperature range	°F (°C)	-22 to +122 (-30 to +50)					
Wind force	Bft (Beaufort)	max. 10					
Protection class barrier housing	—	IP 54					

Table 4: Operating conditions – "Access" series

4.1.4 Operating times

Designation	Unit	Access		Access Pro		Access Select	
			L		L		L
Opening time/ Closing time	s	2.2	4.0	1.3	4.0	1.3	4.0

Table 5: Operating times – "Access" series

Technical data

4.2 Access Pro H

4.2.1 Dimensions and weight

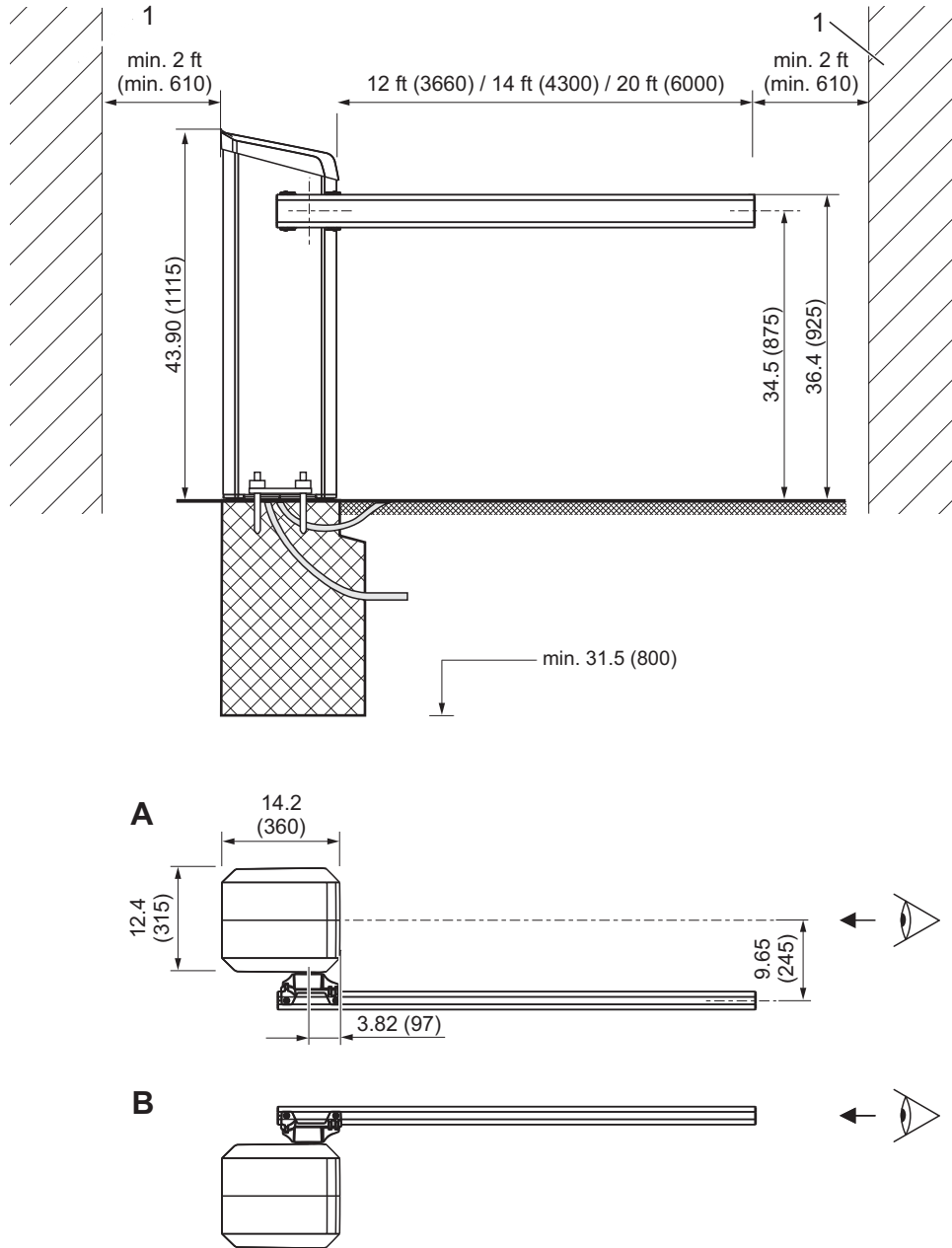

Fig. 4: Dimensions barrier system and barrier arm profile – "Access Pro H" series
 Dimensions in inch or feet are without parenthesis. Dimensions in mm are in parenthesis.

- 1 Object such as wall, building, etc.
- 2 MicroBoom (barrier arm) with octagon boom profile
- A Barrier, left version
- B Barrier, right version

Mag00202a

Designation	Unit	Access Pro H		
		12 (3.66)	15 (4.57)	20 (6.00)
	ft (m)			
Line width	ft (m)	12 (3.66)	15 (4.57)	20 (6.00)
Barrier housing (width x depth x height)	in (mm)	→ See page 34, Fig. 4. 12.4 x 13.6 x 36.0 (315 x 360 x 915)		
Weight barrier housing	lbs (kg)	97 (44)		

Table 6: Dimensions and weight – "Access Pro H" series

4.2.2 Electrical connection

Designation	Unit	Access Pro H		
		12 (3.66)	15 (4.57)	20 (6.00)
	ft (m)			
Supply voltage	V AC	85 to 264		
Frequency	Hz	50 / 60		
Nominal current consumption ¹⁾	A	0.5	0.5	0.5
Max. peak current consumption ²⁾	A	3.0	3.0	3.0
Nominal power consumption ¹⁾	W	25	25	25
Duty cycle	%	100		

1) The values refer to a power supply of 120 V AC / 60 Hz and without accessories.

2) The values refer to a power supply of 120 V AC / 60 Hz, with illumination, service socket not used. Using the service socket in the barrier housing increases the current consumption by 5 A.

Table 7: Electrical connection – "Access Pro H" series

4.2.3 Operating conditions

Designation	Unit	Access Pro H		
		12 (3.66)	15 (4.57)	20 (6.00)
	ft (m)			
Ambient temperature range	°F (°C)	–22 to +122 (–30 to +50)		
Wind force	Bft (Beaufort)	maximal 10		
Protection class barrier housing	—	IP 54		

Table 8: Operating conditions – "Access Pro H"

Technical data

4.2.4 Operating times

Designation	Unit	Access Pro H		
		12 (3.66)	14 (4.3)	20 (6.00)
Opening time/ Closing time	s	4.0	4.0	4.0

Table 9: Operating times – "Access Pro H"

4.3 Parking

4.3.1 Dimensions and weight

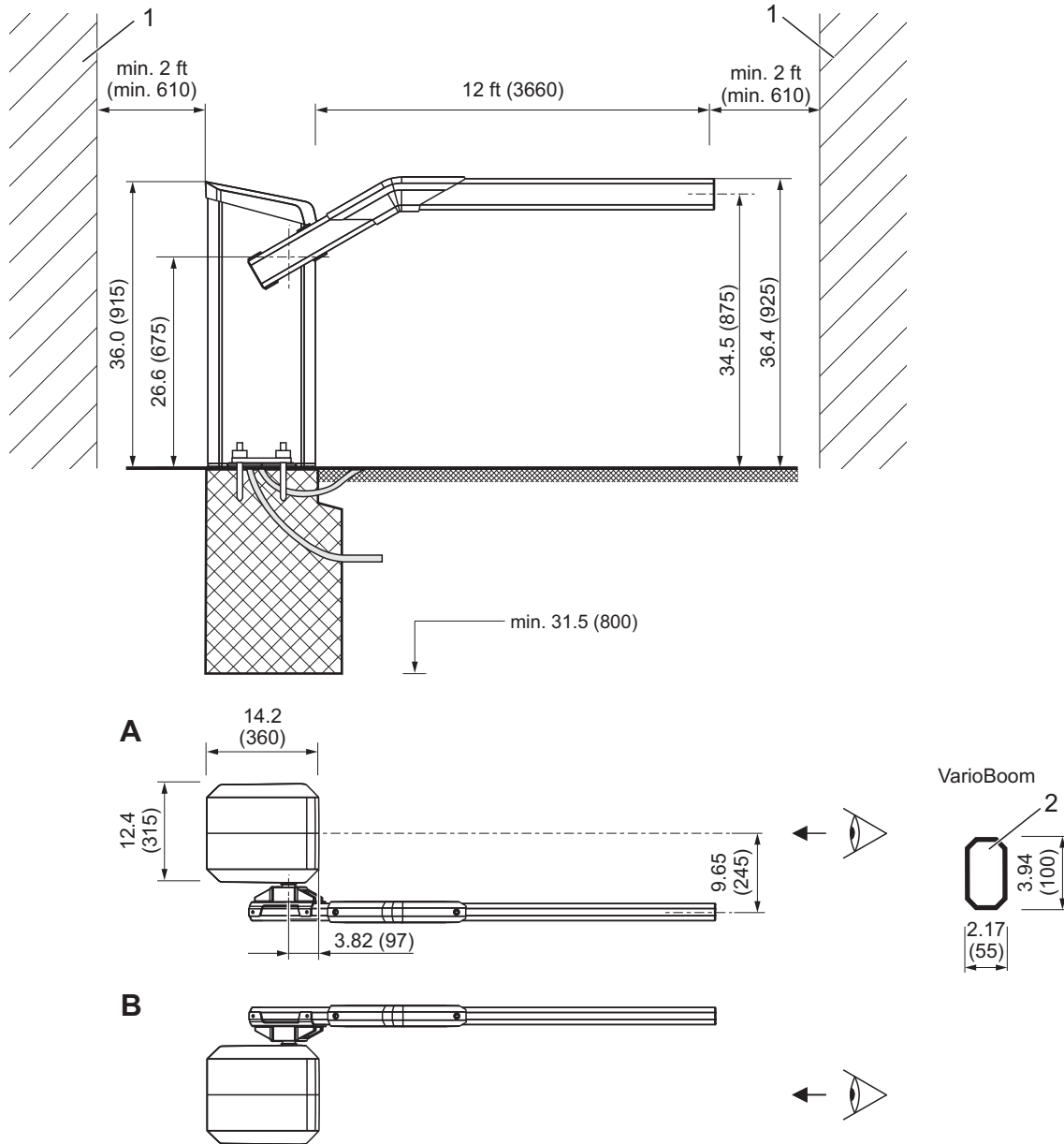

Fig. 5: Dimensions barrier system and barrier arm profile – "Parking" series
 Dimensions in inch or feet are without parenthesis. Dimensions in mm are in parenthesis.

1 Object such as wall, building, etc. → See also page 28, chapter 2.7.

2 MicroBoom (barrier arm) with octagon boom profile

A Barrier, left version

B Barrier, right version

Technical data

Designation	Unit	Parking	Parking Pro	Parking Select
Line width	ft (m)	12 (3.66)	12 (3.66)	12 (3.66)
Barrier housing (width x depth x height)	in (mm)	→ See page 37, Fig. 5. 12.4 x 13.6 x 36.0 (315 x 360 x 915)		
Weight barrier housing	lbs (kg)	88.2 (40)		

Table 10: Dimensions and weight – "Parking" series

4.3.2 Electrical connection

Designation	Unit	Parking	Parking Pro	Parking Select
Supply voltage	V AC	85 to 264		
Frequency	Hz	50 / 60		
Nominal Current consumption ¹⁾	A	1.0	1.5	1.5
Max. peak current consumption ²⁾	A	4.0	5.0	5.0
Nominal power consumption ¹⁾	W	35	95	95
Duty cycle	%	100		

1) The values refer to a power supply of 120 V AC / 60 Hz and without accessories.

2) The values refer to a power supply of 120 V AC / 60 Hz, with illumination, service socket not used. Using the service socket in the barrier housing increases the current consumption by 5 A.

Table 11: Electrical connection – "Parking" series

4.3.3 Operating conditions

Designation	Unit	Parking	Parking Pro	Parking Select
Ambient temperature range	°F (°C)	-22 to +122 (-30 to +50)		
Wind force	Bft (Beaufort)	max. 10		
Protection class barrier housing	—	IP 54		

Table 12: Operating conditions – Series "Parking"

4.3.4 Operating times

Designation	Unit	Parking	Parking Pro	Parking Select
Opening time/ Closing time	s	1.8	1.3	1.3

Table 13: Operating times – "Parking" series

4.4 Toll

4.4.1 Dimensions and weight

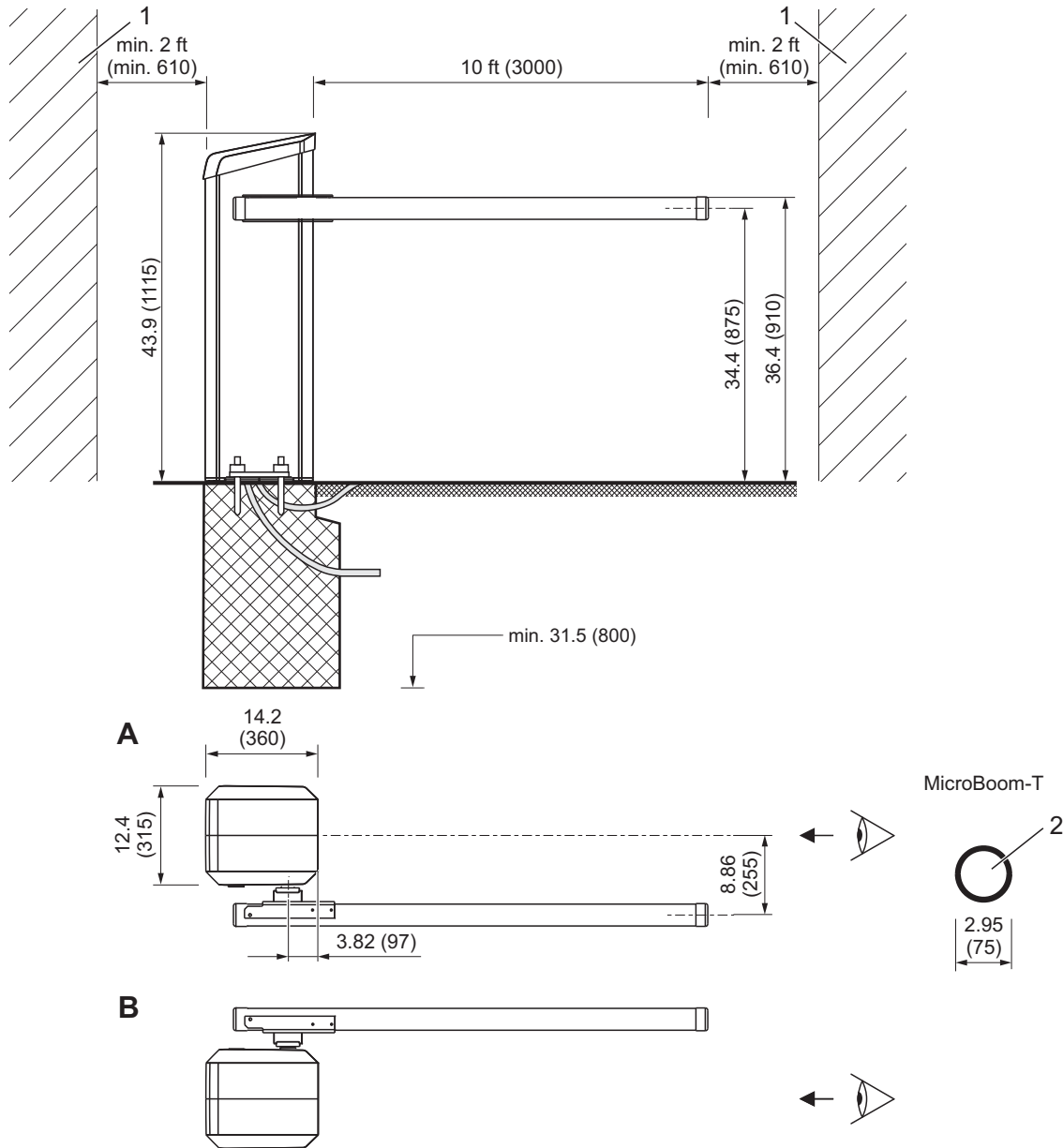

Fig. 6: Dimensions barrier system and barrier arm profile – "Toll" series
 Dimensions in inch or feet are without parenthesis. Dimensions in mm are in parenthesis.

- 1 Object such as wall, building. etc. → See also page 28, chapter 2.7.
 2 Barrier arm "MicroBoom-T" type with round boom profile

- A Barrier. left version
 B Barrier. right version

Technical data

Designation	Unit	Toll	Toll Pro
Line width	ft (m)	10 (3)	
Barrier housing (width x depth x height)	in (mm)	→ See page 43, Fig. 7. 12.4 x 14.7 x 43.9 (315 x 360 x 1115)	
Weight barrier housing	lbs (kg)	92.6 (42)	

Table 14: Dimensions and weight – "Toll" series

4.4.2 Electrical connection

Designation	Unit	Toll	Toll Pro
Supply voltage	V AC	85 to 264	
Frequency	Hz	50 / 60	
Nominal current consumption ¹⁾	A	1.0	1.5
Max. peak current consumption ²⁾	A	6.0	6.5
Nominal power consumption ¹⁾	W	70	115
Duty cycle	%	100	

1) The values refer to a power supply of 120 V AC / 60 Hz and without accessories.

2) The values refer to a power supply of 120 V AC / 60 Hz, with illumination, service socket not used. Using the service socket in the barrier housing increases the current consumption by 5 A.

Table 15: Electrical connection – "Toll" series

4.4.3 Operating conditions

Designation	Unit	Toll	Toll Pro
Ambient temperature range	°F (°C)	-22 to +122 (-30 to +50)	
Wind force	Bft (Beaufort)	max. 10	
Protection class barrier housing	—	IP 54	

Table 16: Operating conditions – "Toll" series

4.4.4 Operating time

Designation	Unit	Toll	Toll Pro
Opening time/ Closing time	s	1.3	0.9

Table 17: Operating time – "Toll" series

4.5 Control unit

Designation		Unit	MGC (MAGNETIC Gate Controller)
Supply voltage		V DC	24
Current consumption		—	max. 1 A, max. 300 mA + current consumption of the different plug-in modules
Power consumption		—	max 24 W, Max. 7.2 W + power consumption of the different plug-in modules
Control device safety		—	1 A T
Output clamp X2	Output voltage	V DC	24
	Max. output current	mA	300
Digital inputs	Number	—	8
	Input voltage	V DC	24 ± 10 %
	Input current	—	< 10 mA per input
	Max. line length without overvoltage module ¹⁾	ft (m)	100 (30)
Digital outputs	Number	—	4 (open collector)
	Switching voltage	V DC	24 ± 10 %
	Max. switching current	mA	100
	Max. line length without overvoltage module ¹⁾	ft (m)	100 (30)
Output relay	Number	—	3 normally-open contact and 3 change-over contacts, isolated
	Max. switching voltage	V AC / DC	30
	Switching current	mA	10 mA to 1 A
	Max. line length without overvoltage module ¹⁾	ft (m)	100 (30)
Display		—	Graphics display, 128 x 65 Pixel
Language display		—	Selectable: German, English, French, Spanish, Italian or Portuguese
Number of slots for plug-in modules		—	5

1) For line lengths exceeding 30 m, overvoltage modules must be installed in front of the terminal clamps.

Table 18: Control unit

Technical data

4.6 Plug-in module "Detector A–B"

Designation	Unit	Plug-in module "Detector A–B"
Current consumption	mA	50
Number of loop detectors	–	2 (A and B)
Inductance range	μH	70 to 500
Number of induction loop sensitivity levels	–	10 levels
Response sensitivity induction loop	%	Selectable: 0.01 to 2.0

Table 19: Plug-in module "Detector A–B"

4.7 Plug-in module "Radio"

Designation	Unit	Plug-in module "Radio"
Current consumption	mA	20
Frequency hand transmitter	MHz	433
HF-Modulation	–	FM/AM (depending on region)
Grant of equipment authorization (Certificate)	–	FCC Identifier: QV2-SMD-53200RX FCC 02-157 → See page 181, chapter 17.

Table 20: Plug-in module "Radio"

5 Design and function

5.1 Design

5.1.1 Access and Parking

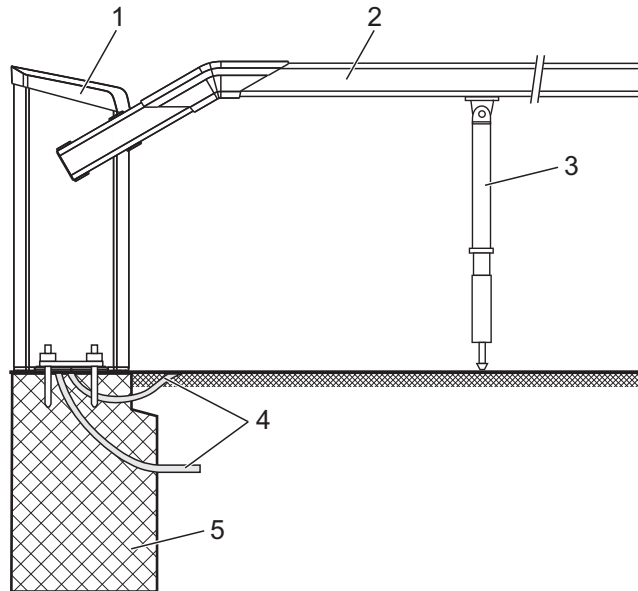

Mag00199

Fig. 7: Barrier system design series "Access" and Series "Parking"

- 1 Barrier housing
- 2 VarioBoom (barrier arm)
- 3 Pendulum support from 15 ft (4.57 m) barrier arm length
- 4 Empty conduits for mains cable, control lines and induction loop
- 5 Concrete foundation with reinforcement

Design and function

5.1.2 Access Pro H

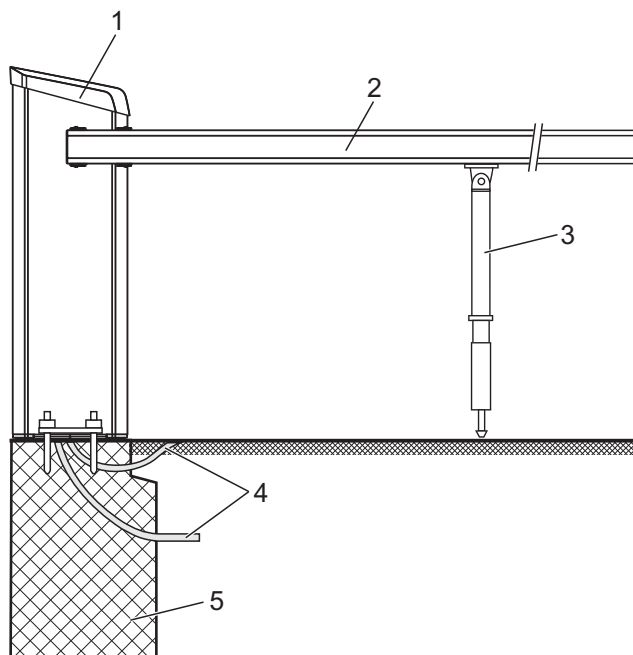

Mag00203

Fig. 8: Design barrier series "Access Pro H"

- 1 Barrier housing
- 2 MicroBoom Access Pro H
- 3 Pendulum support from 15 ft (4.57 m) barrier arm length
- 4 Empty conduits for mains cable, control lines and induction loop
- 5 Concrete foundation with reinforcement

5.1.3 Toll

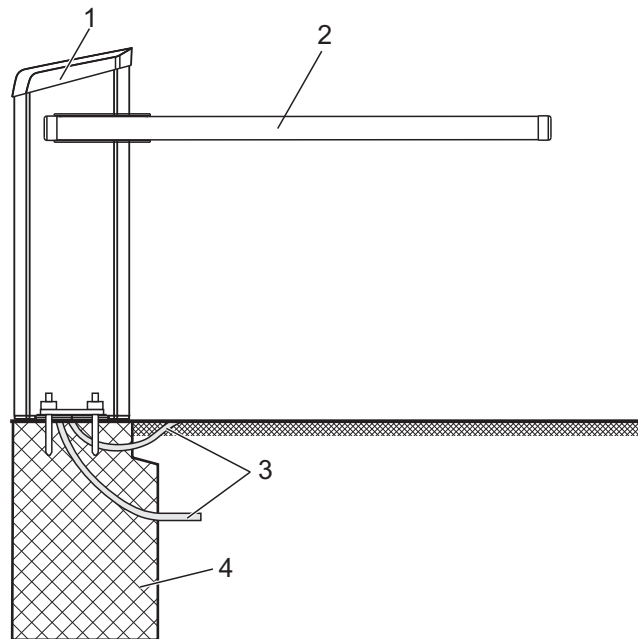

Mag00200

Fig. 9: Design barrier system series "Toll"

- 1 Barrier housing
- 2 "MicroBoom-T" barrier arm
- 3 Empty conduits for mains cable, control lines and induction loop
- 4 Concrete foundation with reinforcement

5.2 Function

The barrier consists of a barrier housing with drive system and a barrier arm.

The drive system consists of an electric motor, control unit, and the lever system. The lever system locks the barrier arm in both end positions. In case of power outage, the barrier arm can easily be moved by hand. Integrated balancing springs in the lever system balance out the boom weight exactly. These balancing springs are pre-set in the factory.

Sensors integrated in the motor supply exact data on every correct position of the barrier arm and thus serve the control unit to control the best acceleration and deceleration.

For the series "Access" and "Parking", the angled barrier arm "VarioBoom" is used, this barrier arm enables driving through even at an opening of only 35°.

For the "Toll" series, the barrier arm is designed as a "Swing Away". That means, if a vehicle drives against the boom, it will snap from its flange. Depending on version, the barrier arm will automatically or by hand be returned to its original position.

Safety facilities like induction loops or safety light barriers must be installed on site in all cases. The safety installations must ensure that the barrier closes only after the vehicle has passed through. Safety installations, such as induction loops can be purchased from MAGNETIC. The safety light barriers must be MAGNETIC ones.

6 Transport and storage

6.1 Safety

Improper transport

⚠ WARNING!	
	<p>WARNING! Danger from improper transport of the barrier arm and housing!</p> <p>The weight of the barrier arm or housing can severely injure a person!</p> <p>Therefore:</p> <ul style="list-style-type: none"> – Have them transported by specialists only. – Use lifting gear or forklift with a suitable pallet. – Use suitable lifting gear (loops, etc.) for lifting the barrier arm and barrier housing. The lifting gear must be designed for the respective weights. – Lifting and carrying the barrier arm and housing from the pallet should be done by a minimum of two people.

Heavy weight

⚠ WARNING!	
	<p>WARNING! Risk of injury when lifting heavy objects alone!</p> <p>The weight of heavy objects can severely injure a person!</p> <p>Therefore:</p> <ul style="list-style-type: none"> – Lifting and carrying the barrier arm and housing from the pallet should be done by a minimum of two people.

Transport and storage

Improper transport

NOTICE!	
	<p>NOTICE!</p> <p>The barrier system can be damaged by improper transport!</p> <p>Substantial material damages can result from improper transport.</p> <p>Therefore:</p> <ul style="list-style-type: none"> – Have all transport work performed by trained personnel. – When unloading the packages and during in-house transportation always proceed with greatest care and caution. – Observe the symbols on the packaging. – Observe the dimensions of the barrier system. – Loading, unloading as well as moving the barrier system must take place with greatest care. – Only remove packaging directly before assembly.

Personal protective equipment

The following must be worn during all transport work:

- Work clothes
- Protective gloves
- Safety shoes
- Protective helmet.

6.2 Transport inspection

Immediately check the delivery after receipt for completeness and transport damages.

Proceed as follows in the case of outwardly recognisable transport damage:

- Do not accept the delivery or only under reserve.
- Note the extent of damage on the transport documents or on the delivery note of the forwarder.
- Lodge complaint.



NOTE!

Lodge a complaint for each defect, as soon as it is recognized. Compensation claims can only be submitted within the valid complaint periods.

6.3 Transport

Barrier housing and barrier arm are delivered separately.

The lifting gear must be designed for the weight of the barrier housing and barrier arm.

For transport barrier modules refer to the safety notes on page 47, chapter 6.1.

For future transports:

- Secure loose cables.
- Secure against vibrations.
- Securely fasten the barrier housing and barrier arm prior to transport (e.g. screw it onto a pallet).
- Transport and put down barrier housing and barrier arm with a forklift and lift with suitable lifting gear.

6.4 Storage

Store the barrier or packages under the following conditions:

- Do not store outdoors.
- Store dry and dust free.
- Do not expose to aggressive media.
- Protect against solar irradiation.
- Avoid mechanical vibrations.
- Storage temperature: –22 to +158 °F (–30 to +70 °C)
- Relative humidity: max. 95 %, non-condensing
- Check the general condition of all components and packaging regularly, if they are stored for longer periods than 3 months.

Design notes for induction loops

7 Design notes for induction loops

→ For assembly and inspection, see page 61, chapter 8.4.

Please observe following points when dimensioning the induction loops:

- Induction loops respond only to metal. The mass is thereby not important, but the size of the loop's surface, which will be covered by the metal part is.
- The induction loops must not respond to persons or objects with a small metal portion like a bicycle for instance.
- Safety loops must secure the danger area underneath the barrier arm throughout the entire length.
- Opening loops must be installed right in front of the safety loop. The maximum distance between safety loop and opening loop must be not greater than max. 3.28 ft (1.0 m).

Arrangement passenger car loops – standard

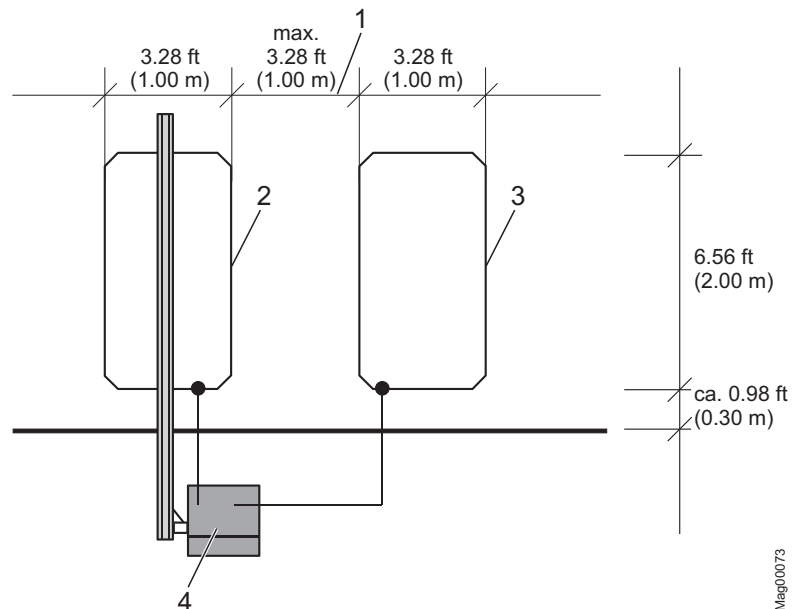
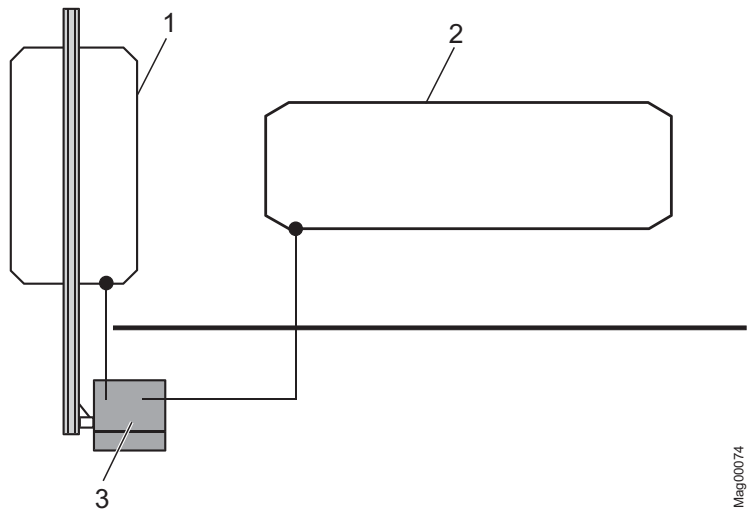

Fig. 10: Passenger car loop

- 1 Maximum distance between opening loop and safety loop
- 2 Safety loop
- 3 Opening loop
- 4 Barrier

Arrangement passenger car loops – passage with long opening loop

Mag00074

Fig. 11: Passenger car loops – passage with long opening time

- 1 Safety loop
- 2 Opening loop
- 3 Barrier

Due to a long opening loop vehicles can drive through without needing to stop.

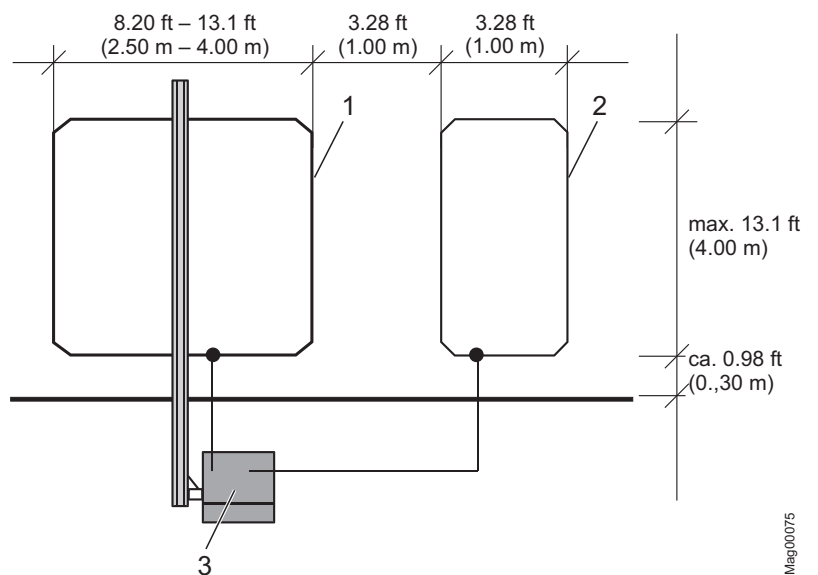
Arrangement of truck loops

Mag00075

Fig. 12: Lorry loops

- 1 Safety loop
- 2 Opening loop
- 3 Barrier

For truck passages the safety loop in the direction of travel must be at least 8.2 ft (2.5 m) long.

Design notes for induction loops

Arrangement of truck/ passenger car loops

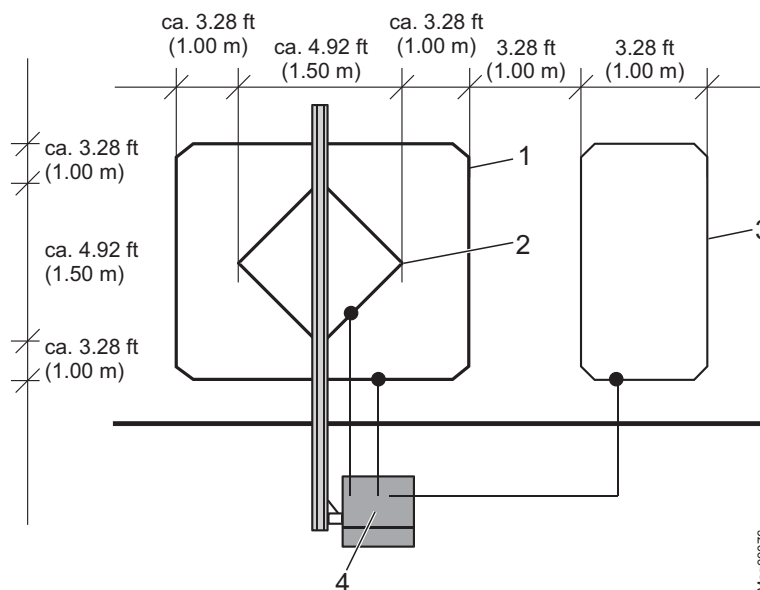

Fig. 13: Lorry/passenger car loops

- 1 Safety loop truck (inductance L1)
- 2 Safety loop passenger car (inductance L2)
- 3 Opening loop truck and passenger car
- 4 Barrier

Observe overall inductance " L_{total} ". For calculation, see below.

For combined truck/passenger car loops following points must be additionally observed:

- The winding direction of the inner safety loop for passenger cars must be identical to the outer safety loop for trucks. Meaning, the sensitivity in the middle between outer and inner loop is then at its maximum.
- Outer and inner loop can be both connected with one detector channel, as the case may be.
- The overall inductance determines, whether the truck and the passenger car loop have to be implemented as series or as parallel circuit. Always lead both feed lines into the barrier housing. The overall inductance must be between 70 and 500 μ H.

Calculation of the overall inductance for series circuits

$$L_{total} = L1 + L2$$

Calculation of the overall inductance for parallel circuits



$$L_{total} = \frac{L1 \cdot L2}{L1 + L2}$$

8 Assembly and installation



8.1 Safety

→ See also safety notes on page 20, chapter 2.6 "Occupational safety and special dangers".

Non-intended use



 WARNING!	
	<p>WARNING! Non-intended use is dangerous!</p> <p>Any use of the barriers other than intended and/or in a different manner can cause hazardous situations.</p> <p>The barrier system is intended for installation only on crossings used for vehicles. Pedestrians must be supplied with a separate access opening. The pedestrian access opening shall be designed to promote pedestrian usage. Locate the barrier such that persons will not come in contact with the vehicular passageway during the entire path of travel of the vehicular barrier.</p>

Danger of crushing and shearing, barrier arm

 WARNING!	
	<p>WARNING! Danger of crushing and shearing when the barrier opens or closes!</p> <p>When a barrier opens or closes, the barrier arm may lead to severe crushing or injury!</p> <p>Therefore:</p> <ul style="list-style-type: none"> – Keep a safety distance of at least 2 ft (610 mm) between the barrier arm and other objects, such as walls, masonry or houses. → See also page 28, chapter 2.7 – Install the barrier system only when all exposed pinch points are eliminated or guarded. – Assemble and install barrier system according to Fig. 14. – Controls intended for user activation must be located at least 6 ft (1.83 m) away from any moving part of the barrier and where the user is prevented from reaching over, under, around or through the barrier to operate the controls. Outdoor or easily accessible controls shall have a security feature to prevent unauthorized use.

Assembly and installation

General

 WARNING!	
	<p>WARNING! Danger by inappropriate installation! Inappropriate installation can cause severe injuries! Therefore:</p> <ul style="list-style-type: none">– Only specialist personnel or electrical specialists must perform any assembly and installation tasks.– Prior to work, ensure that there is sufficient assembly space.– Pay attention to tidiness and cleanness at the assembly site! Loosely stacked or lying around components and tools are accident sources.– Comply with specifications for foundations and reinforcement.– Ensure correct arrangement and fit on all assemblies and components.– Install the indicated fastening elements correctly.

Personal protective equipment

The following must be worn during all assembly and installation work:

- Work clothes
- Protective gloves
- Safety shoes
- Protective helmet.

8.2 Required steps

The following steps are to be completed prior to assembly and installation:

- Laying the foundation with reinforcement for the barrier and install empty conduits.
- Set up foundation for light barrier post and empty conduits.
- Installing induction loops.

The following procedures have to be observed during assembly and installation:

- Unpack barrier and accessories.
- Mount barrier housing on the foundation.
- Mount light barrier post on the foundation.
- Mount safety light barrier.
- Assemble barrier arm (VarioBoom only).
- Mount edge protection.
- Mount barrier arm.
- Adjust balancing springs.
- Align barrier housing and light barrier post.
- Assemble and install signalling device.
- Arrange electrical connections. → See page 91, chapter 9.

Assembly and installation

8.3 Foundation and empty conduits

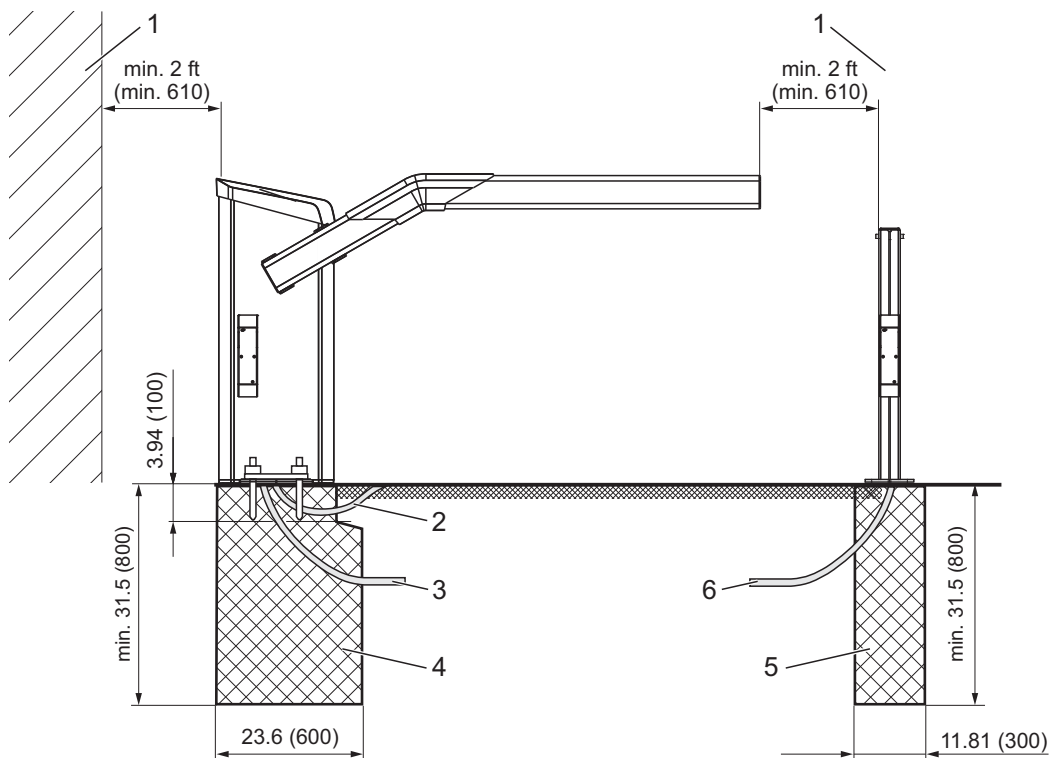

Fig. 14: Assembly boom system

Dimensions in inch or feet are without parenthesis. Dimensions in mm are in parenthesis.

- 1 Object such as wall, building, etc.
Keep a safety distance of at least 2 ft (610 mm) between the barrier arm and other objects, such as walls, masonry or houses. → See page 28, chapter 2.7
- 2 Posts, e.g. nesting posts, place post centre at a distance of 50 mm to the barrier arm tip
- 3 Empty conduit for induction loop connection
- 4 One empty conduit each for mains cable and control lines
- 5 Foundation with reinforcement grid for barrier housing
- 6 Optional: Empty conduit for safety light barriers, connection line receiver
- 7 Optional: Foundation for nesting post or light barrier post, nesting post displayed here

8.3.1 Foundation and empty conduits for the barrier

Assembly site

The assembly site must meet the following requirements:

- The barrier must be visible from the operating person.
- The barrier must not be put up where there is a danger of flooding.
- Keep a safety distance of at least 2 ft (610 mm) between the barrier arm and objects such as walls, buildings, etc.
→ See page 28, chapter 2.7 and page 56, Fig. 14

Foundation and reinforcement

The foundation must meet the following requirements:

→ See page 56, Fig. 14 and page 58, Fig. 15.

- Have sufficient load-carrying capacity.
(concrete foundations: C35/45 XD3 XF2)
- Water cement value: 0.5
- Foundation depth: at least 31.5 in (800 mm), frost-protected foundation depth to be adjusted to the local situation.
- Foundation section: 17.7 in x 23.6 in (450 mm x 600 mm)
- Reinforcing mesh as shown in figure Fig. 16.
- Surface has to be non-combustible material.

Empty conduits

The empty conduits must meet the following requirements:

→ See page 56, Fig. 15.

- Separate empty conduits for mains cable and control line
Diameter: 1.14 ft (29 mm) each
- Optional empty conduit for induction loop.
Diameter: 1.14 (29 mm) each
- Conduits have to be planned to a sufficient length.



NOTE!

To provide a trouble-free operation use separate conduits for control lines and mains cables.

Assembly and installation

Laying the foundation, Installing empty conduits

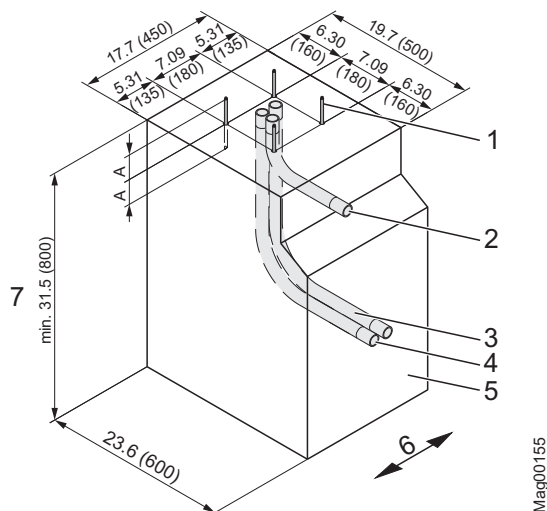

Fig. 15: Foundation plan

Dimensions in inch or feet are without parenthesis. Dimensions in mm are in parenthesis.

- 1 Foundation anchor (4 pcs.)
- 2 Optional when using loop connection; empty conduit for loop connection, diameter: 1.14 in (29 mm)
- 3 Empty conduit for induction loop, diameter: 1.14 in (29 mm)
- 4 Empty conduit for control lines, diameter: 1.14 (29 mm)
- 5 Concrete foundations (C35/45 XD3 XF2)
- 6 Roadway
- 7 Foundation depth: at least 31.5 in (800 mm), frost-protected foundation depth to be adjusted to the local situation.

1. Dig foundation hole pursuant to Fig. 14 and Fig. 15.

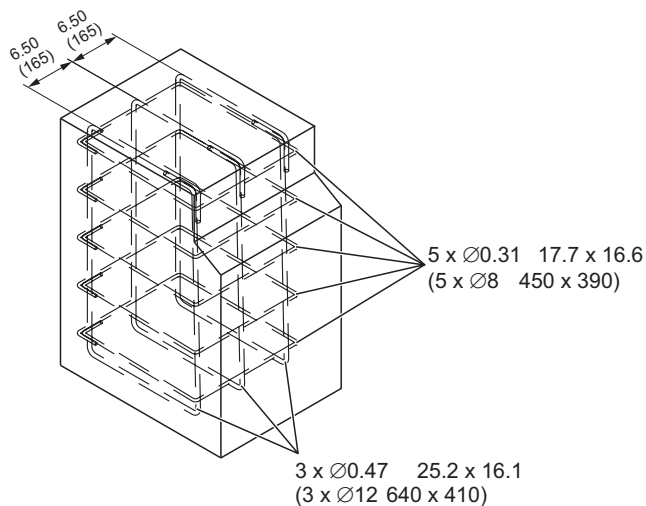

Fig. 16: Reinforcement grid

Dimensions in inch or feet are without parenthesis. Dimensions in mm are in parenthesis.

2. Place reinforcement grid pursuant to Fig. 16 in the foundation hole.

3. Place empty conduits pursuant to Fig. 15 in the foundation hole.
4. Close empty conduits to prevent water from entering.
5. Fill concrete foundation pursuant to Fig. 14.
6. Create flat line in the base area. The following requirements must be fulfilled:
 - Level and horizontal.
 - Surface deviation: max. 1 in/ft² (1 mm/m²)
7. Let concrete cure.
8. Apply moisture protection agent to concrete surface.

**NOTE!**

We recommend applying moisture protection either in the form of sealing sludges such as 1100 Hansit or ready-made solution such as Sikagard® 703 W or deepdry® to the concrete surface before housing assembly. Moisture protection prevents entering of moisture into the housing from the concrete floor.

8.3.2 Foundation and empty conduits for light barrier post

Assembly site

The nesting post and light barrier post must not be put up where there is a danger of flooding.

Foundation

The foundation must meet the following requirements:

→ See page 56, Fig. 14 and page 60, Fig. 17.

- Have sufficient load-carrying capacity.
(concrete foundations: C35/45 XD3 XF2)
- Water cement value: 0.5
- Foundation depth: at least 31.5 in (800 mm), frost-protected foundation depth to be adjusted to the local situation.
- Foundation section: 11.81 x 11.81 in (300 mm x 300 mm)

Empty conduit

If the barrier system is equipped with a light barrier, an empty conduit must be installed for the transmitter connection line. Conduits have to be planned to a sufficient length.

Assembly and installation

Laying the foundation, installing empty conduits

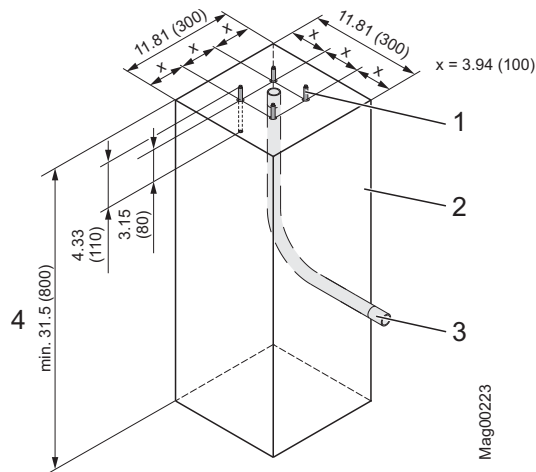

Fig. 17: Foundation plan for light barrier post
 Dimensions in inch or feet are without parenthesis. Dimensions in mm are in parenthesis.

- 1 Foundation anchor (4 pcs.)
- 2 Concrete foundations (C35/45 XD3 XF2)
- 3 Optional for light barriers:
Empty conduit for receiver connection line
- 4 Foundation depth: at least 800 mm, frost-protected
foundation depth to be adjusted to the local situation.

1. Dig foundation hole pursuant to Fig. 14 and Fig. 17.
2. Place empty conduit pursuant to Fig. 17 in the foundation hole.
3. Close empty conduit to prevent water from entering.
4. Fill concrete foundation pursuant to Fig. 17.
5. Create flat line in the base area. The following requirements must be fulfilled:
 - Level and horizontal.
 - Surface deviation: max. 1 in/ft² (1 mm/m²)
6. Let concrete cure.

8.4 Assembly and installation of induction loops

Depending on the application safety installations must be installed on site. Induction loops, light barriers, etc. can be used as safety installations.

The safety installations must ensure that the barrier closes only after the vehicle has passed through. Safety installations, such as induction loops can be purchased from MAGNETIC.

8.4.1 Directions for the assembly and installation of induction loops

On barriers with an automatic closing function induction loops are used for the detection of vehicles. The loop underneath the barrier arm always serves as monitor and closing loop. Meaning, as long as a vehicle is standing on the loop, the barrier stays open. Only after the vehicle has left the loop will the barrier be closed.

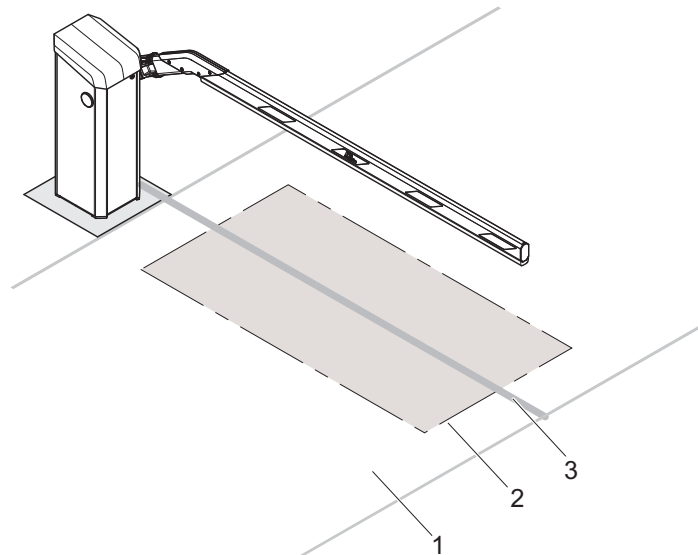

Mag00204

Fig. 18: Arrangement example of an induction loop for passenger car operation

- 1 Roadway
- 2 Induction loop
- 3 Projection of the barrier arm onto the subsurface with a standard installation of the loop

→ The induction loop setup depends on the application case. For other application cases, refer to page 50, chapter 7.

Assembly and installation

Please observe following points when installing the induction loop:

Loop geometry and clearances

- Install the loop symmetrically to the barrier arm. Please make sure that the barrier arm is attached to the side of the barrier housing.
- The clearance of the safety loop for passenger cars in front of, and behind the barrier arm must be at least 19.7 in (500 mm). The safety loop for trucks must be dimensioned larger. → See page 31, Fig. 3 to page 39, Fig. 6.
- The distance of the induction loop from the roadside should be about 11.8 in to 19.7 in (300 to 500 mm).
- Install opening loops right in front of the safety loop. The clearance between opening loop and safety loop must be not greater than 3.28 ft (1 m) for trucks and passenger cars.
- If there are iron reinforcements, ramp heating etc. in the roadway, the induction loop must have a clearance of at least 1.97 in (50 mm) from those. Metals in the proximity of the induction loop affect the response sensitivity.
- Avoid direct contact of induction loops with reinforcement and ramp heating.
- Install induction loops with sufficient clearance from sliding gates, roller grilles etc.

Installation and ground conditions

- Please make sure when moulding or installing that the loop can not move anymore once it is in operation. Any geometric alteration will act as inductance change, which will set the detector to an error state.
- Brittle road surfaces, loose pavements, gravel paths etc. are not suited for the application of induction loops.

Feed line

- The feed line to the loop must not exceed 49.2 ft (15 m).
- The loop connection cable must protrude about 4.9 ft (1.5) m from the foundation.
- Shorten the feed line to the loop to the proper length. The feed line must by no means be coiled.
- The feed line must be twisted up to right in front of the terminals of the loop detector with ca. 6 twists per feet.

8.4.2 Induction loops

The induction loops are available as ready assembled cables in various lengths from several manufacturers. Make sure that they meet the specification described in these operating instructions.

Alternatively a loop can be manufactured from single wire. The following requirements must be fulfilled:

- Wire cross section: 18 to 16 AWG (0.75 to 1.5 mm²)
- Inductivity of the loop: 70 to 500 μH. This is equivalent to a loop with 3 to 6 windings.
- When using hot pouring compounds, such as bitumen temperature resistant loop cables/strands must be used.

8.4.3 Testing induction loops

To verify the contact resistance, insulation resistance, and inductance of the loop these properties must be measured after installation:

- Contact resistance: 0.8 to 2.0 ohms
- Insulation resistance to earth: > 1 Mohm.
- Inductivity of the loop: 70 to 500 μH

If the values are not within the specified ranges, the loop is defective.

8.4.4 Installing induction loops in bitumen, asphalt, or concrete

1. Cut a 1.97 in (50 mm) deep groove into the surface or asphalt using a cutting disc. The groove must be equally deep at every point. According to Fig. 14 the corners of the groove must be cut in a 45° angle.

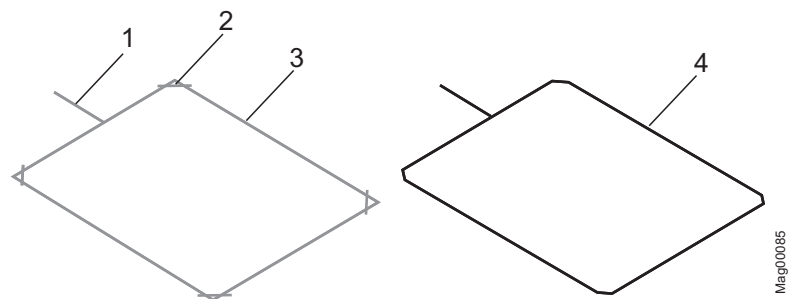

Fig. 19: Installing induction loop in bitumen, asphalt, or concrete

- 1 Groove for induction loop feed line
- 2 Corners cut diagonally
- 3 Groove for induction loop
- 4 Induction loop

Assembly and installation

2. Lay the loop carefully into the groove and push it down by means of a blunt object, such as a piece of wood. The insulation must by no means be damaged.
3. To avoid slipping of the loop, fix the loop using small wooden wedges. Remove the wooden wedges later on.
4. Push the loop feed line through the empty conduit in place into the barrier housing.
5. Measure the induction loop according to chapter 8.4.3.
6. We recommend to cover the inserted loop using quartz sand. Make sure that at least 0.98 in (25 mm) remain between the upper edge of the roadway and the quartz sand for the potting compound.
7. Seal the groove with the potting compound.
 - The temperature resistance of the loop must match the temperature of the potting compound.
8. Allow the potting compound to cure.

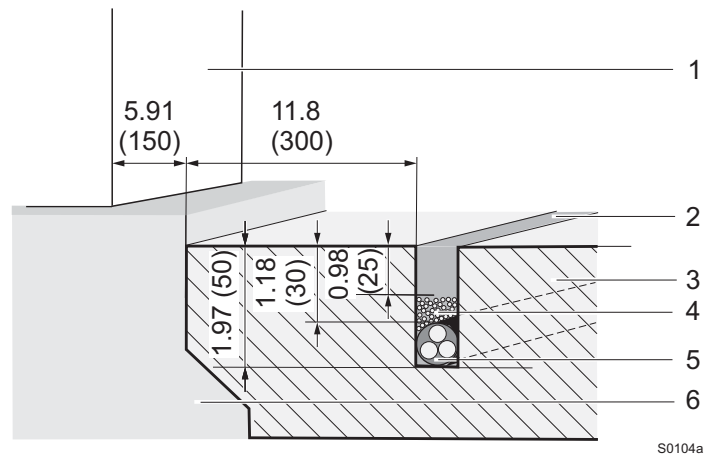
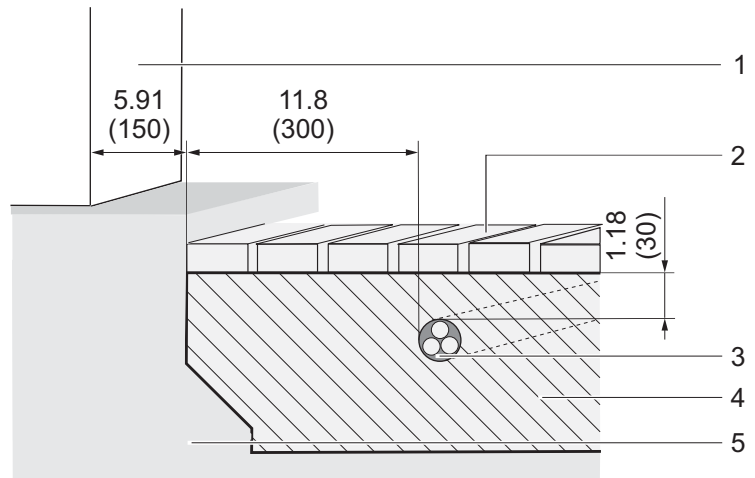

Fig. 20: Installing induction loop in bitumen, asphalt, or concrete
 Dimensions in inch are without parenthesis. Dimensions in mm are in parenthesis.

- 1 Barrier housing
- 2 Groove with potting compound
- 3 Asphalt surface
- 4 Quartz sand filling
- 5 Loop cable
- 6 Foundation

8.4.5 Installing induction loops under interlocking stone paving



S0105a

*Fig. 21: Installing an induction loop under interlocking stone paving
Dimensions in inch are without parenthesis. Dimensions in mm are in parenthesis.*

- 1 Barrier housing
- 2 Paving
- 3 Loop cable
- 4 Sand bed
- 5 Substructure

When installing induction loops under interlocking stone paving, following points must be observed additionally:

- Use only pre-assembled cables.
- Install the induction loop in sand only. The induction loop must not be installed in gravel or split.
- The induction loop must not slip or shift or be damaged during later vehicle traffic.
- Keep a minimum clearance between paving and loop cable of approx. 1.18 in (30 mm).

8.5 Unpacking

The individual packages are packed according to the expected transport conditions. Only environment-friendly materials have been used for the packaging.

The packaging should protect the individual components against transport damages, corrosion, etc up to the assembly. Therefore do not destroy the packaging and remove only directly before assembly.

1. Unpack barrier.
2. Set up barrier housing vertically.
3. Lay down barrier arm.
4. Unpack and lay out accessories.
5. Separate material according to type and size and recycle them after use.

8.6 Assemble housing

The barrier housing is attached by 4 foundation anchors via 2 attachment profiles. The attachment profiles are included in delivery.

Requirements mounting material

MAGNETIC Automation Corporation recommends using \varnothing 3/8" anchor bolts. → Refer to the anchor bolt manufacturers installation requirements.

1. The foundation must have cured.

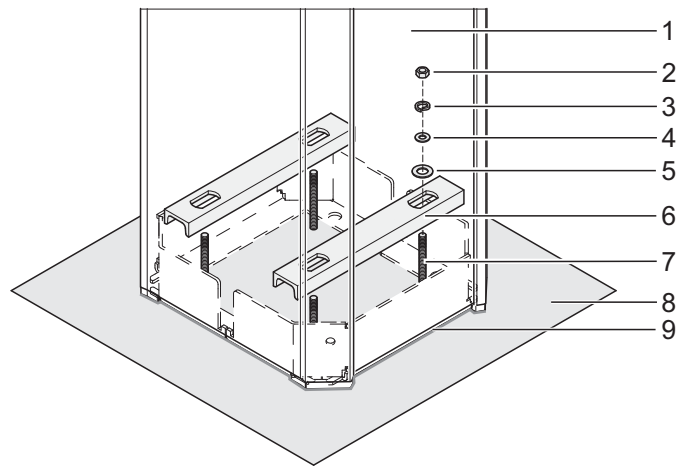

Mag00205

Fig. 22: Assemble housing

- 1 *Barrier housing*
 - 2 *Nut*
 - 3 *Spring washer*
 - 4 *Washer d8,4*
 - 5 *Washer d13*
 - 6 *Mounting profile*
 - 7 *Foundation anchor*
 - 8 *Foundation*
 - 9 *Silicon sealant*
2. Drill holes for the foundation anchors according to the foundation plan, page 58, Fig. 15. In compliance with the indicated sizes.
 - Drill-hole distance: 7.01 in (180 mm), square alignment
 - Depth: 3.15 in (80 mm)
(At this drilling depth, a minimum tensile strength of 1.98 kpf (8.8 kN) must be guaranteed.)
 3. Place four foundation anchors.
 4. Set up barrier housing upright on foundation.
 5. Barrier housing attached to mounting profile on the foundation with foundation anchors. Tighten nuts slightly for this.
 6. Align barrier housing. Tighten nuts firmly. If a nesting post or light barrier post is installed, observe page 86, chapter 8.14.
 7. Seal barrier housing with silicon sealant.

Assembly and installation

8.7 Assemble light barrier post

The light barrier post is attached with 4 foundation anchors each.

Requirements mounting material

MAGNETIC Automation Corporation recommends using \varnothing 3/8" anchor bolts. → Refer to the anchor bolt manufacturers installation requirements.

Assemble light barrier post

1. The foundation must have cured.
2. Drill holes for the foundation anchors according to the foundation plan, page 60, Fig. 17. In compliance with the indicated sizes.
 - Drill-hole distance: 3.94 in (100 mm), square alignment
 - Depth: 3.15 in (80 mm)
(At this drilling depth, a minimum tensile strength of 2.02 kpf (9 kN) must be guaranteed.)
3. Set four foundation anchors.
4. Set up post upright on foundation.
5. Attach the post to the foundation with the anchor bolts and tighten the nuts securely.

8.8 Assemble safety light barrier

Only MAGNETIC safety light barriers must be used.

8.8.1 Assemble transmitter

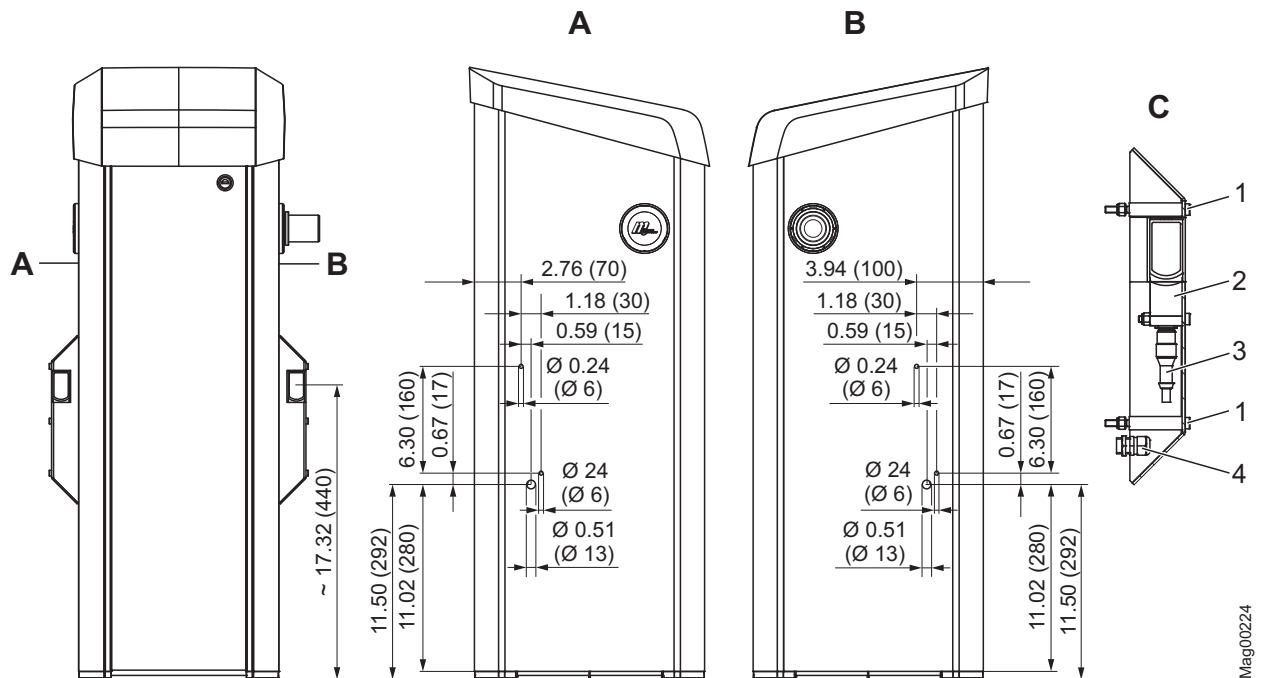

Fig. 23: Assemble the receiver's light barrier housing on the barrier housing
 Dimensions in inch or feet are without parenthesis. Dimensions in mm are in parenthesis.

- A View A
 B View B
 C Light barrier housing transmitter

- 1 Hexagon socket screws 5 AF
 2 Transmitter
 3 Transmitter connection line
 4 Cable screw connection

1. Drill holes for the light barrier housing according to Fig. 14.
2. Mount the cable screws at the housing with locknuts.
3. Connect connection line for transmitter to the control unit.
4. Guide connection line through cable screws.
5. Mount light barrier housing to housing with the hexagon socket screws 5 AF.

Assembly and installation

8.8.2 Assemble receiver

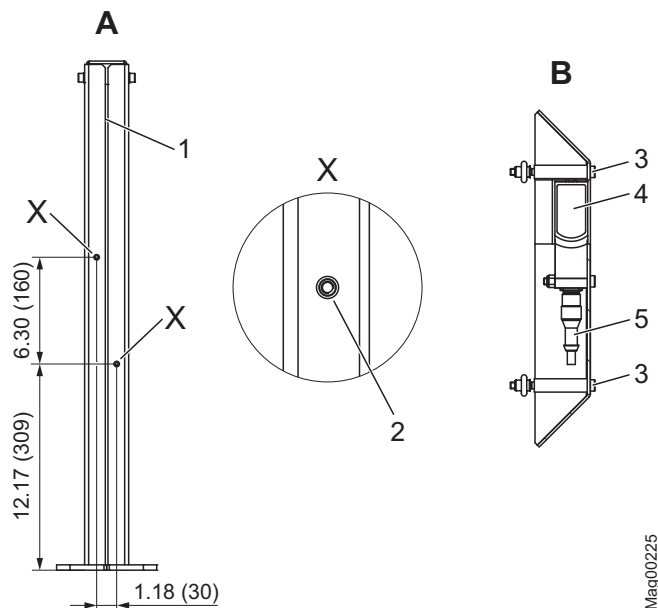

Fig. 24: Assemble the receiver's light barrier housing on the post
Dimensions in inch or feet are without parenthesis. Dimensions in mm are in parenthesis.

- A Light barrier post
B Light barrier housing

- 1 Gap
2 Drill holes for blind rivet nut
3 Hexagon socket screws 5 AF
4 Receiver
5 Receiver connection line

1. Press the two blind rivet nuts into the two intended bores at the post.
2. Guide the connection line for receiver through the gap in the post.
3. Connect connection line for receiver to the receiver.
4. Mount light barrier housing to housing with the hexagon socket screws 5 AF.
5. Close empty conduits with construction foam to prevent water from entering them.

8.9 Assemble barrier arm type "VarioBoom"

The barrier arm type "VarioBoom" is delivered in two parts.



- Short barrier arm profile with assembled connection plates, half-shells and end caps.
- Long barrier arm profile

The mounting material is included in delivery.

1. Remove transport rubber bands.
2. Disassemble the two half-shells from the short barrier arm profile.
3. Slide long barrier arm profile over the two connection plates.
4. Attach long barrier arm profile to both connection plates with the 4 Torx. The larger bores must remain free.
5. Attach the two half-shells with the washers and the hexagon socket screws.

8.10 Assemble edge protection

Missing edge protection at the barrier arm

 WARNING!	
	<p>WARNING! Danger from missing edge protection at the barrier arm!</p> <p>Missing edge protection at the barrier arm may cause severe or lethal injury for persons, bicyclers and cabriolet drivers when the barrier arm closes!</p> <p>Therefore:</p> <ul style="list-style-type: none">– Assemble edge protection.– If the edge protection is damaged, it must be replaced immediately.



NOTE!

If you use a pendulum support, observe that you must mount part of the edge protection in front of the pendulum support and part of the edge protection behind the pendulum support.

Assembly and installation



The edge protection is included in the delivery loosely in 6.56 ft (2 m) pieces. If the barrier was ordered with the light strips option, the barrier arm is delivered with the mounted edge protection.

The number of edge protections is according to the length of the long barrier arm profile.

1. Measure the length of the long barrier arm profile.
2. Shorten edge protection to the required length with a saw. When the length of the barrier arm profile is, for example, 11.5 ft (3.5 m), saw off one edge protection to 4.92 ft (1.5 m).
3. Moisten lower half of the barrier arm onto which the edge protection is pushed with water.
4. Slide edge protection in the barrier arm groove.
5. Slide further edge protections into the intended groove until the edge protection ends flush with the barrier arm.

8.11 Assembling flange and barrier arm

Danger of injury

 CAUTION!	
	<p>CAUTION! Danger of injury!</p> <p>There is a danger of injury when mounting the barrier arm.</p> <p>Therefore:</p> <ul style="list-style-type: none"> – Barrier arms as of a length of 14.8 ft (4.5 m) must be installed by two persons. We recommend also installing shorter barrier arms with two persons.

8.11.1 Type "VarioBoom" and "MicroBoom"

Do not grease

NOTICE!	
	<p>NOTICE! Improper lubrication of components, in particular the counter bearing or flange shaft, may lead to damage of the equipment!</p> <p>Therefore:</p> <ul style="list-style-type: none"> – Do not grease the counter bearing and flange shaft.

1. Secure barrier danger area e.g. with barrier tape.
2. Remove the barrier housing hood.
3. Remove the barrier housing door.

WARNING!
Danger of crushing between barrier arm and barrier housing!

4. Switch off power supply. Ensure that the system is powered down. Secure against reactivation. The balancing springs in the lever system are relaxed (boom raised).
5. Remove end cap from the barrier arm.

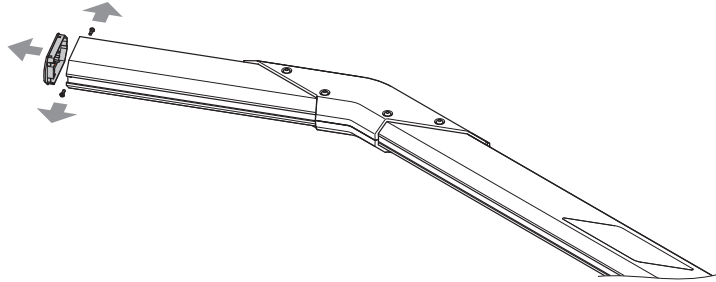

Mag00170

Fig. 25: Disassemble end cap

6. Slide a slot nut into the groove at the underside of the barrier arm. Place a slot nut on the upper side of the barrier arm.

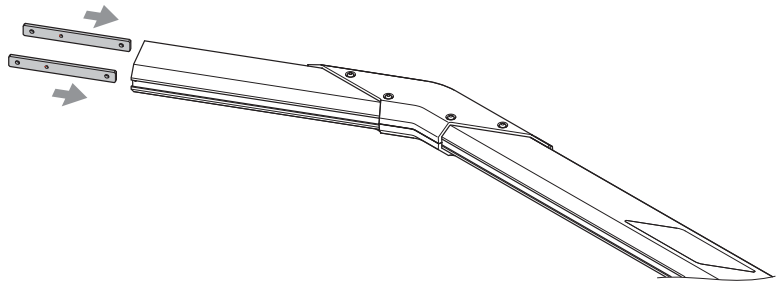

Mag00171

Fig. 26: Assemble slot nuts

7. Attach the flange with the 4 hexagon socket screw and the two slot nuts to the barrier arm. The shorter protrusion of the flange must point towards the barrier arm end. Tighten screws twice in sequence to ensure that all screws are tightened correctly.
 - Use a torque wrench with hexagon socket: 5 AF
 - Tightening torque: 11.801 lbf ft (16 Nm)

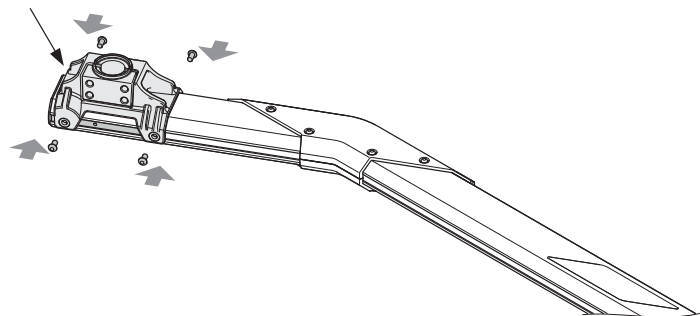

Mag00173

Fig. 27: Assembling flange

Assembly and installation

8. Install end cap to the barrier arm.

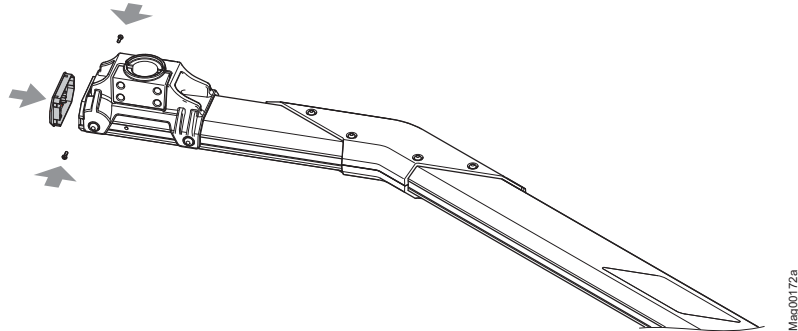

Fig. 28: Install end cap

9. Push barrier arm with pre-assembled flange onto the flange shaft.

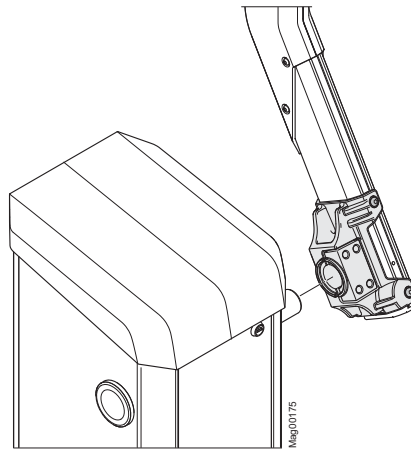



Fig. 29: Assemble flange with barrier arm

10. Align barrier arm vertically.
11. Install the flange on the flange shaft using the 4 hexagon socket screws. To tighten the screws evenly.
- Use a torque wrench with hexagon socket: 10 AF
 - Tightening torque: 55.318 lbf ft (75 Nm)
12. Close screws and threaded bores with the included grey plastic covers.

13. Push the barrier into the top-most position. The clamping lever must be at the stop for the "open" position. If required, push straight through the upper tool bore with a tool to press the lever arm from the dead point. → See page 171, chapter 13.5.
14. Check the vertical alignment of the barrier arm with a level and correct with the hexagon socket screws at the flange if necessary.
15. Switch on power supply.
16. Switch the "Service" switch on the control unit. The LED lights red. The display backlighting flashes.
→ See page 123, chapter 10.7.7 Mode "Service".
17. Close the control unit with the middle right button  at the control unit.
18. Check the horizontal alignment of the barrier arm with a level and correct with the hexagon socket screws at the flange if necessary.
19. Switch the "Service" switch on the control unit. The LED must light green.
20. Switch off power supply.
21. Install the barrier housing door.
22. Attach and lock the barrier housing hood.

8.11.2 Barrier arm type "MicroBoom-T"

1. Secure barrier danger area e.g. with barrier tape.
2. Remove the barrier housing hood.
3. Remove the barrier housing door.



WARNING!

Danger of crushing between barrier arm and barrier housing!

4. Switch off power supply. Ensure that the system is powered down. Secure against reactivation. The balancing springs in the lever system are relaxed (boom raised).

Assembly and installation

5. Install the flange on the flange plates with the 2 hexagon socket screws 8 AF. Make sure:
 - Tighten the screws evenly with a tightening torque of 44.254 lbf ft (60 Nm).
 - That the air gap between flange and flange plate must be consistent.

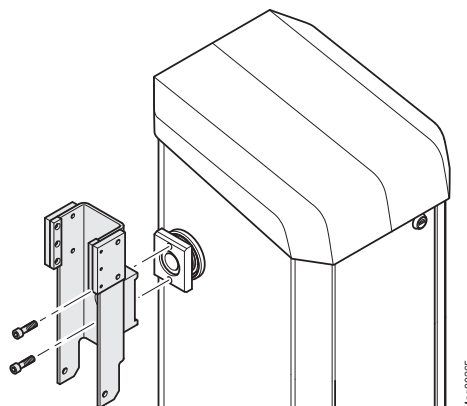

Fig. 30: Install flange to flange plate

6. Slide steel sleeve into the intended bore in the barrier arm.
7. Place barrier arm in the flange so that the barrier arm can be assembled.
8. Assemble barrier arm with hexagon screw, washer and hexagon nut.

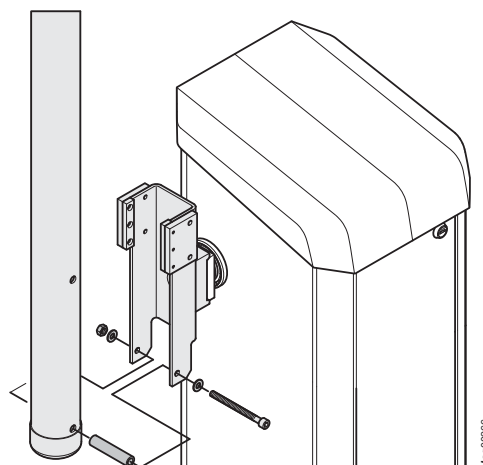





Fig. 31: Assemble barrier arm

9. Push the barrier into the top-most position. The clamping lever must be at the stop for the "open" position. If required, push straight through the upper tool bore with a tool to press the lever arm from the dead point. → See page 171, chapter 13.5.
10. Check the vertical alignment of the barrier arm with a level and correct with the hexagon socket screws at the flange if necessary.
11. Switch on power supply.
12. Switch the "Service" switch on the control unit. The LED lights red. The display backlighting flashes.
→ See page 123, chapter 10.7.7 Mode "Service".
13. Close the barrier with the middle right button  at the control unit.
14. Check the horizontal alignment of the barrier arm with a level and correct with the hexagon socket screws at the flange if necessary.
15. Switch the "Service" switch on the control unit. The LED must light green.
16. Switch off power supply.
17. Install the barrier housing door.
18. Attach and lock the barrier housing hood.

Assembly and installation

8.12 Conversion "left version" – "right version" (VarioBoom and MicroBoom)

Danger of injury

 CAUTION!	
	<p>CAUTION! Danger of injury!</p> <p>There is a danger of injury when mounting the barrier arm.</p> <p>Therefore:</p> <ul style="list-style-type: none"> – Barrier arm as of a length of 14.8 ft (4.5 m) must be installed by two persons. We recommend also installing shorter barrier arms with two persons.

Do not grease

NOTICE!	
	<p>NOTICE! Improper lubrication of components, in particular the counter bearing or flange shaft, may lead to damage of the equipment!</p> <p>Therefore:</p> <ul style="list-style-type: none"> – Do not grease the counter bearing and flange shaft.

All MHTM™ MicroDrive barriers are available as "left version" and "right version". → See type code, page 30 and as of page 31, Fig. 3 to Fig. 6.

If required, you can also remove the barrier arm yourself from one side of the barrier housing and replace it on the other.

1. Secure barrier danger area e.g. with barrier tape.
2. Remove the barrier housing hood.
3. Remove the barrier housing door.



WARNING!

Danger of crushing between barrier arm and barrier housing!

4. Switch off power supply. Ensure that the system is powered down. Secure against reactivation. The balancing springs in the lever system are relaxed (boom raised).
5. The barrier must be open. Open barrier arm manually if required.
6. Disassemble flange from the flange shaft together with the barrier arm. For this, loosen the 4 hexagon socket screws 10 AF at the flange.
7. Remove the flange with the barrier arm.

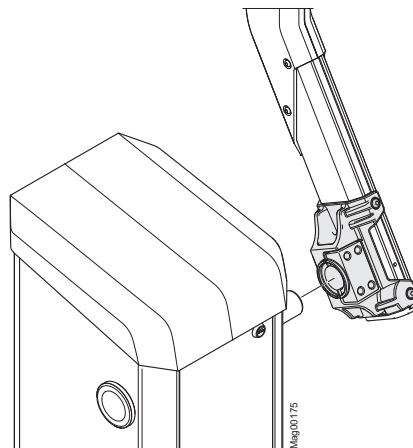

Fig. 32: Disassemble flange with barrier arm

8. Remove the v-ring from the flange shaft.

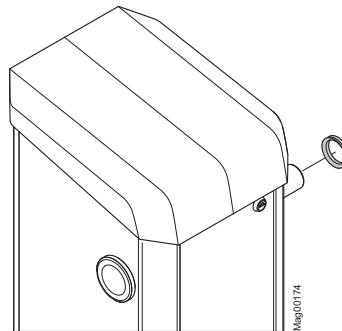

Fig. 33: Remove the v-ring

9. Slightly loosen the two hexagon socket screws 10 AF of the clamping lever at the flange shaft. Do not remove the hexagon socket screws.

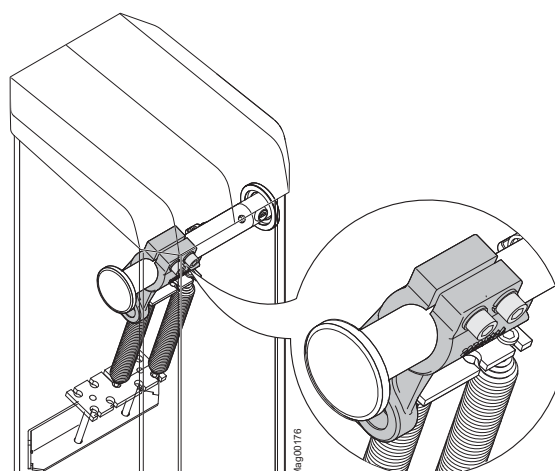



Fig. 34: Loosen hexagon socket screws at the clamping lever



Assembly and installation

10. Unhook the balancing springs in the lever system. For this, press a tool straight through the upper tool bore. The lever arm is pressed from the upper dead point. → See page 171, chapter 13.5.
11. Remove the flange shaft cover disc of the barrier housing. Push a long rod through the flange shaft for this and slightly push it against the cover.
12. Push the flange shaft to the other side by turning. The flange shaft must be flush with the counter bearing on the side where the barrier is not mounted. The flange shaft points out of the barrier housing by approx. 2.44 in (62 mm) on the other side.
13. Tighten the two hexagon socket screws of the clamping lever at the flange shaft.
 - Use a torque wrench with hexagon socket: 10 AF
 - Tightening torque: 88.508 lbf ft (120 Nm)
14. Hook in the balancing springs in the lever system.
15. Slip the v-ring over the flange shaft. The sealing lip points towards the barrier housing. → See also page 79, Fig. 33.
16. Remove flange from the barrier arm. For this, loosen the 4 hexagon socket screws 5 AF at the barrier arm.
17. Attach the flange on the other side of the barrier arm. Observe position of the two slot nuts. The shorter protrusion of the flange must point towards the barrier arm end. → See also page 74, Fig. 27.
 - Use a torque wrench with hexagon socket: 5 AF
 - Tightening torque: 11.801 lbf ft (16 Nm)
18. Push barrier arm with pre-assembled flange onto the flange shaft.
19. Align barrier arm vertically.
20. Install the flange on the flange shaft using the 4 hexagon socket screws. To tighten the screws evenly.
 - Use a torque wrench with hexagon socket: 10 AF
 - Tightening torque: 55.318 lbf ft (75 Nm)
21. Close screws and threaded bores with the included grey plastic covers.
22. Insert the cover disc for the flange shaft.
23. Push the barrier into the top-most position. The clamping lever must be at the stop for the "open" position. If required, push straight through the upper tool bore with a tool to press the lever arm from the dead point. → See page 171, chapter 13.5.
24. Check the vertical alignment of the barrier arm with a level and correct with the hexagon socket screws at the flange if necessary.
25. Switch on power supply.

26. Switch the "Service" switch on the control unit. The LED lights red. The display backlighting flashes.
→ See page 123, chapter 10.7.7 Mode "Service".
27. Close the barrier with the middle right button  at the control unit.
28. Check the horizontal alignment of the barrier arm with a level and correct with the hexagon socket screws at the flange if necessary.
29. Switch the "Service" switch on the control unit. The LED must light green.
30. Switch off power supply.
31. Install the barrier housing door.
32. Attach and lock the barrier housing hood.

8.13 Check and set the balancing springs in the lever system

Danger of crushing, lever system

 WARNING!	
	<p>WARNING! Danger of crushing at opened barrier housing at the lever system!</p> <p>The lever system in the barrier housing can cause serious crushing injuries!</p> <p>Therefore:</p> <ul style="list-style-type: none"> – Balancing springs in the lever system must only be checked and adjusted by specialised personnel. – Balancing springs must only be checked and adjusted with the power supply turned off – Wear protective gloves if necessary.

The lever system has balancing springs that exactly balance the barrier arm weight. These balancing springs are pre-set in the factory. The precise setting must be performed after assembly of the barrier arm and before commissioning.

The lever force is determined not only by the spring tension but also by the number of springs used and the spring rate. MAGNETIC uses two spring types. Depending on application case, you will have to set the spring tension, remove the springs, use additional springs or use springs with a different spring rate.

→ Also see page 84, chapter 8.13.2.

In the "Power behaviour" menu, you can set the barrier behaviour in case of voltage failure. → See page 137, chapter 10.10.9. The settings in this menu do not influence the settings of the balancing springs.

Assembly and installation

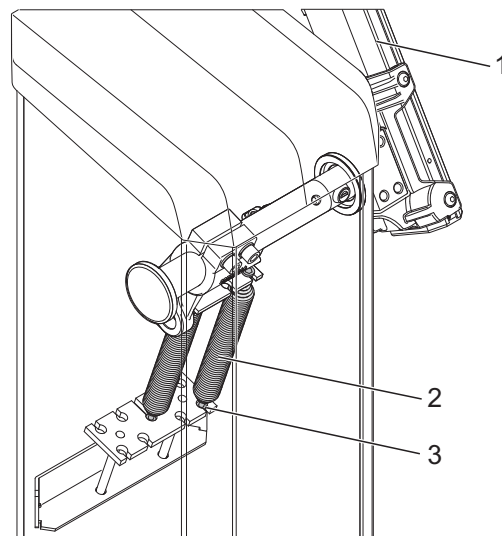

Fig. 35: Balancing springs in the lever system.

- 1 Barrier arm
- 2 Balancing spring
- 3 Screw with locknuts

8.13.1 Setting balancing springs

Check and adjust balancing springs

Check balancing springs with the motor warm from operation.

1. Secure barrier danger area e.g. with barrier tape.



WARNING!

Danger of crushing between barrier arm and barrier housing!

2. Switch off power supply. Ensure that the system is powered down. Secure against reactivation.
3. Place barrier arm in the 30° position manually. If required, push straight through the upper tool bore with a tool to press the lever arm from the dead point.
→ See page 171, chapter 13.5.
4. Let go of barrier arm.
 - If the barrier arm stays in the 30° position, the balancing springs are set correctly.
 - If the barrier arm does not stay in the 30° position, the balancing springs must be adjusted.

Adjust balancing springs:

5. Remove the barrier housing hood.
6. Remove the rear barrier housing door.
7. Adjust springs with a wrench via the screws with locknuts.
 - Barrier arm angle > approx. 30°:
This balancing springs are tightened too far.
 - Barrier arm angle < approx. 30°:
This balancing springs are not tightened enough.
8. Install the barrier housing door.
9. Attach and lock the barrier housing hood.

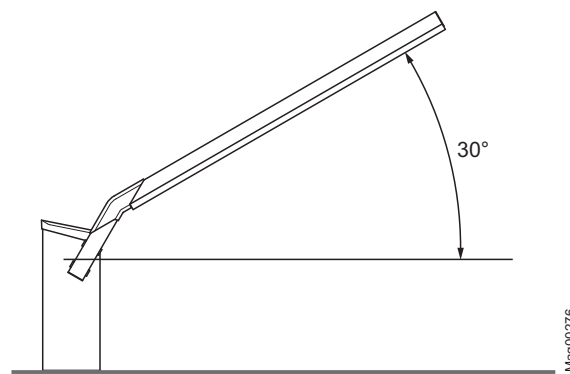

Fig. 36: Opening angle barrier arm 30°

Assembly and installation

8.13.2 Overview table balancing springs



NOTE!

The following overview tables "Balancing springs" do not take into consideration any attachment parts. For barrier arms with attachment parts, the required number of springs may deviate from the number of springs in the overview table.

The following overview tables apply for barriers with VarioBoom.

Overview table balancing springs for barriers with VarioBoom and without pendulum support

Line width	Number springs weak	Number springs strong
4.9 to 5.6 ft (1.5 to 1.7 m)	1	–
5.9 to 7.6 ft (1.8 to 2.3 m)	2	–
7.9 to 9.5 ft (2.4 to 2.9 m)	3	–
9.8 to 11.2 ft (3.0 to 3.4 m)	4	–
11.5 to 12.8 ft (3.5 to 3.9 m)	5	–
13.1 to 14.1 ft (4.0 to 4.3 m)	6	–
14.4 to 15.1 ft (4.4 to 4.6 m)	7	–
15.4 to 16.4 ft (4.7 to 5.0 m)	8	–
16.7 to 17.4 ft (5.1 to 5.3 m)	9	–
17.7 ft (5.4 m)	5	2
18.1 to 19.0 ft (5.5 to 5.8 m)	5	3
19.4 to 19.7 ft (5.9 to 6.0 m)	6	3

Table 21: Overview table balancing springs for barriers with VarioBoom and without pendulum support

Overview table balancing springs for barrier with VarioBoom and with pendulum support

Line width	Number springs weak	Number springs strong
11.5 to 11.8 ft (3.5 to 3.6 m)	6	–
12.1 to 12.8 ft (3.7 to 3.9 m)	7	–
13.1 to 14.4 ft (4.0 to 4.4 m)	8	–
14.8 to 15.4 ft (4.5 to 4.7 m)	9	–
15.8 ft (4.8 m)	5	2
16.1 to 17.4 ft (4.9 to 5.3 m)	5	3
17.7 to 18.4 ft (5.4 to 5.6 m)	6	3
18.7 to 19.0 ft (5.7 to 5.8 m)	5	4
19.4 to 19.7 ft (5.9 to 6.0 m)	4	5

Table 22: Overview table balancing springs for barriers with VarioBoom and with pendulum support

The following overview tables apply for barriers with MicroBoom.

Overview table balancing springs for barriers with MicroBoom and without pendulum support

Line width	Number springs weak	Number springs strong
4.9 to 6.6 ft (1.5 to 2.0 m)	1	–
6.9 to 8.2 ft (2.1 to 2.5 m)	2	–
8.5 to 10.2 ft (2.6 to 3.1 m)	3	–
10.5 to 11.8 ft (3.2 to 3.6 m)	4	–
12.1 to 13.1 ft (3.7 to 4.0 m)	5	–
13.5 to 14.4 ft (4.1 to 4.4 m)	6	–
14.8 to 15.4 ft (4.5 to 4.7 m)	7	–
15.8 to 16.7 ft (4.8 to 5.1 m)	8	–
17.1 to 17.7 ft (5.2 to 5.4 m)	9	–
18.1 ft (5.5 m)	5	2
18.4 to 19.4 ft (5.6 to 5.9 m)	5	3
19.7 ft (6.0 m)	6	3

Table 23: Overview table balancing springs for barriers with MicroBoom and without pendulum support

Overview table balancing springs for barriers with MicroBoom and with pendulum support

Line width	Number springs weak	Number springs strong
11.5 to 12.5 ft (3.5 to 3.8 m)	6	–
12.8 to 13.1 ft (3.9 to 4.0 m)	7	–
13.5 to 14.8 ft (4.1 to 4.5 m)	8	–
15.1 to 16.7 ft (4.6 to 4.8 m)	9	–
16.1 ft (4.9 m)	5	2
16.4 to 17.7 ft (5.0 to 5.4 m)	5	3
18.1 to 18.7 ft (5.5 to 5.7 m)	6	3
19.1 to 19.4 ft (5.8 to 5.9 m)	5	4
19.7 ft (6.0 m)	4	5

Table 24: Overview table balancing springs for barriers with MicroBoom and with pendulum support

Assembly and installation

The following overview table applies for barriers with MicroBoom-T.

Overview table balancing springs for barriers with MicroBoom-T and without pendulum support

Lane width	Number springs weak	Number springs strong
4.9 to 7.9 ft (1.5 to 2.4 m)	1	–
8.2 to 9.8 ft (2.5 to 3.0 m)	2	–

Table 25: Overview table balancing springs for barriers with MicroBoom-T and without pendulum support

8.14 Align barrier housing and light barrier post

Falling components

⚠ WARNING!



WARNING!
Risk of injury from falling components!

Falling components such as the barrier housing can cause severe injury!

Therefore:

- When aligning the barrier housing and light barrier post, loosen the attachment screws only slightly.
- Tighten the attachment screws again after alignment.

Alignment conditions for light barrier

Transmitter and receiver of the light barrier must be aligned with each other for an object to be securely detected. For final alignment, transmitter and receiver must be electrically connected.
→ See page 97, chapter 9.4.4.

1. Slightly loosen the barrier housing and post attachment screws.
2. Align barrier housing and post with each other.
3. Tighten the barrier housing and post attachment screws again.
4. Seal barrier housing with a silicon sealant according to page 67, Fig. 22.

8.15 Installing warning signs

Warning signs for the barrier

A minimum of two warning signs have be installed, one on each side of the barrier where easily visible. Two warning signs for the barrier are part of delivery.



Fig. 37: Apply prohibition signs, shown here for barrier type "Access/Parking"

Warning signs for the barrier arm

A minimum of two warning signs have be installed, one on each side of the barrier where easily visible. Two warning signs for the barrier arm are part of delivery.



Fig. 38: Warning signs for each side of the barrier arm

8.16 Check assembly and installation

The following points must be checked after assembly and installation of the barrier:

- Are all foundation anchors firmly fixed?
- Are all screws firmly tightened
- Have all barrier housing covers been properly assembled?
- Are the warning signs installed?

9 Electrical connection

9.1 Safety

→ See also safety notes on page 20, chapter 2.6 "Occupational safety and special dangers".

Electric voltage –
inadequate qualification

⚠ DANGER!	
	<p>DANGER! Mortal danger by electric voltage! Risk of injury in case of inadequate qualification!</p> <p>Therefore:</p> <ul style="list-style-type: none"> – Only electrical specialists may carry out work on the electrical system. Electrical specialists are able, due to their technical training, knowledge and experiences as well as knowledge of the relevant standards and regulations, to execute tasks on electrical systems and to independently recognize possible hazards. In Germany, the electrical specialist must comply with the provisions of accident prevention regulation BGV A3 (e.g. master electrical fitter). Appropriate regulations apply in other countries. The regulations valid there must be observed. The installation is to be made by a professional installer according to NFPA 70 National Electrical Code and Local Code.

Electric voltage



⚠ DANGER!	
	<p>DANGER! Mortal danger by electric voltage!</p> <p>Touching live parts can be lethal. Damage to the insulation or to individual components can be lethal.</p> <p>Therefore:</p> <ul style="list-style-type: none"> – Switch off the power supply immediately in case of damage to the insulation and arrange repair. – Only electrical specialists may carry out work on the electrical system. – Switch off power supply and secure against reactivation before performing any work. Test for absence of voltage! – Never bypass or deactivate fuses. – When replacing fuses observe the correct amperage specification. – Keep moisture and dust away from live parts. Moisture or dust may cause a short circuit. If the electrical connection is established during precipitation, e.g. rain or snow, penetration of moisture must be prevented by suitable measures, such as a protective cover.

General

⚠ WARNING!	
	<p>WARNING! Danger by inappropriate installation!</p> <p>Inappropriate installation can result in severe and lethal injuries.</p> <p>Therefore:</p> <ul style="list-style-type: none"> – Only electrical specialists must perform any electrical installation tasks. – Pay attention to tidiness and cleanliness at the assembly site! Loosely stacked or lying around components and tools are accident sources. – Tighten all screws correctly.

Electrical connection

Hot surfaces

 CAUTION!	
	<p>CAUTION! Danger of burns!</p> <p>The motor surface may be hot. Touching this hot surface can lead to burns.</p> <p>Therefore:</p> <ul style="list-style-type: none"> – Do not touch these hot surfaces. – After switching off the power supply wait some minutes until the motor has cooled down. – Wear protective gloves if necessary.

Electromagnetic interference

NOTICE!	
	<p>NOTICE! Electromagnetic interferences may cause malfunctions of the barrier or adjacent devices!</p> <p>The barrier is approved for industrial, residential, commercial and business use. Operation in other electro-magnetic environmental conditions may cause interferences or malfunctions.</p> <p>Therefore:</p> <ul style="list-style-type: none"> – Place control lines and mains cables into separate conduits – Use cables according to the electrical circuit plan. – Only install and apply additional parts approved by MAGNETIC. – The electrical and electronically additional parts must be EMC verified and must not exceed the indicated EMC limits.

Personal protective equipment

The following must be worn during all installation work:

- Work clothes
- Protective gloves
- Safety shoes
- Protective helmet.

9.2 Installing electrical protective devices

The safety installations that are required according to regional and local regulations must be provided by the customer. Usually these are:

- Ground fault circuit interrupter (GFCI)
- Circuit-breaker
- Appropriate listed 2-pole main switch.

9.3 Connecting the mains supply

Electrical voltage

⚠ DANGER!	
	<p>DANGER! Danger to life from electric shock!</p> <p>If the mains supply is not connected to the terminal clamps correctly, loosens from the terminal clamps and touches the housing or door, there is a direct danger to life from electric shock.</p> <p>Therefore:</p> <ul style="list-style-type: none">– Have work at the electrical system only performed by electricians.– Connect mains supply according to the following description.– Install electrical protective devices according to chapter 9.2, national and local codes.– Perform proper grounding.



NOTE!

*The wire cross-section of the mains line must be between 16 and 12 AWG (1.5 and 4 mm²).
Observe national provisions on line length and associated cable cross-section.*

Electrical connection



DANGER!

Mortal danger by electric voltage!

Strip-off cable and core insulation – preparation of the wiring

1. Disconnect barrier system power supply. Ensure that the system is powered down. Secure against reactivation.
2. Strip-off mains supply and cores according to the following figure.

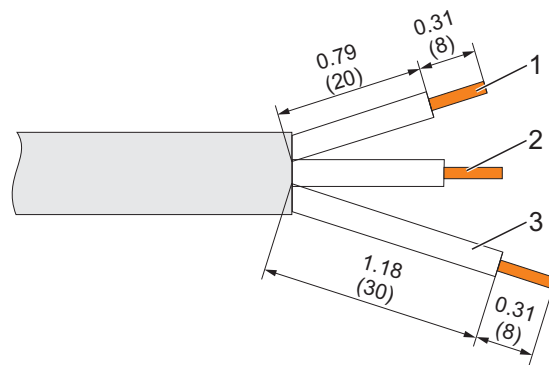

Mag00201

Fig. 39: Strip-off the mains supply
Dimensions in inch or feet are without parenthesis. Dimensions in mm are in parenthesis

- 1 Phase
- 2 Neutral conductor
- 3 Ground conductor

Mains supply placement

3. Connect mains supply to the provided terminal clamps (X1: L/N/PE) of the barrier housing according to the following figures. → See also page 183, chapter 18.1.
 - Place mains supply properly in the barrier housing. The line must be wired so that no damage could occur due to moving parts.
 - Attach mains supply to the metal tabs via 2 cable ties.

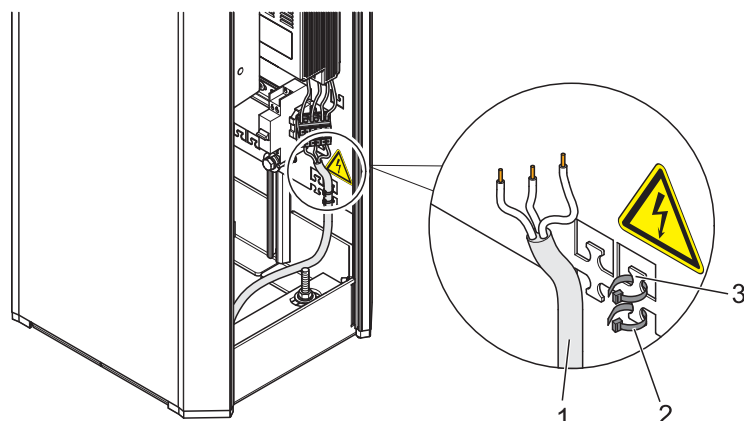

Mag00179a

Fig. 40: Mains supply placement

- 1 Mains supply
- 2 Cable tie
- 3 Cable tie metal tabs

Connecting mains supply

Fig. 41: Connecting the mains supply

- 1 Terminal clamps for mains supply
- 2 Phase L
- 3 Neutral conductor N
- 4 Ground conductor PE

9.4 Connect customer's control lines (signalling devices)

The following connections are available for control and feedback on customer's side:

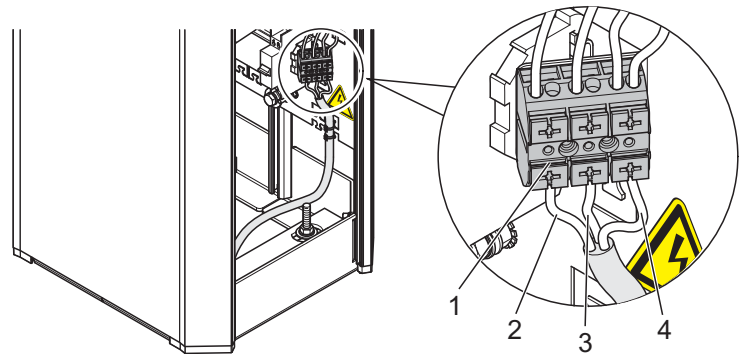
- 8 Digital inputs for controlling the barrier.
- 4 Digital outputs to feed back information.
- 6 Relays outputs to feed back information. 3 Relays are normally-open contacts (NO) and 3 relays are change-over contacts.



DANGER!

Mortal danger by electric voltage!

1. Disconnect barrier system supply voltage. Ensure that there is no voltage applied. Secure against reactivation.
2. Guide control lines into the connection space through the cable openings.
 - Place control lines properly in the barrier housing. The control lines must not get into moving components.
 - Attach control lines clamps and cable ties. The clamps can be removed from the rail by slight compression and relocated in the desired position. The cable ties can be attached to the metal tabs.
3. Connect control lines according to wiring diagram. Control lines must be wired so that no damage could occur due to moving parts.
 - See page 183, chapter 18.1 "Wiring diagrams".

Connecting the control lines

Electrical connection

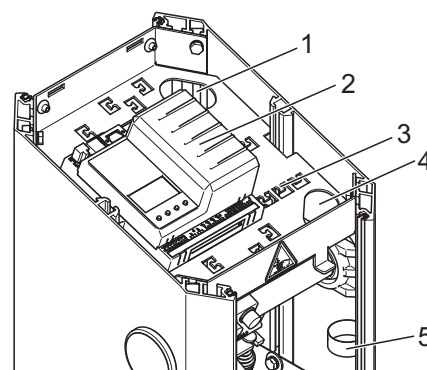

Mag00180

Fig. 42: Connecting the control lines

- 1 Cable opening rear
- 2 Control unit
- 3 Cable tie metal tabs
- 4 Cable opening front
- 5 Cable clamps

9.4.1 Connecting safety devices

As safety devices, you must connect safety loops or safety light barriers to the control unit. Safety loops must only be connected to monitor vehicles. Only MAGNETIC safety light barriers must be used.

If you connect a safety loop, the barrier closes only after the safety loop is clear. If you connect a safety light barrier, the barrier closes only after the safety light barrier is clear.

The danger area of 2 ft (610 mm) as defined in chapter 2.7 must be maintained at any time, even in case additional safety devices are installed.

9.4.2 Plausibility check of the safety devices

**NOTE!**

The plausibility check is deactivated in barriers of the series "Toll" and barriers in deadman operation with a closing speed of ≥ 2.2 seconds.

To prevent the barrier from being operated without safety devices, a plausibility check of the safety devices is performed.

The plausibility check inspects whether at least one safety device is present and whether the safety device works correctly in operation.

When the voltage supply is switched on, it is verified that at least one safety device was passed by a vehicle within three barrier openings. In operation, the number is increased to ten barrier openings.

If the plausibility check fails, the barrier is decommissioned for reasons of safety. The message "Safety device missing" appears on the display.

**NOTE!**

The input function "Safety devices" must only be used for additional safety devices. The input function is not considered for the plausibility check. A safety loop always has to be connected to the detector module or a testable safety light barrier to the clamps X11 and X20.

Electrical connection

9.4.3 Connecting safety loop

The safety loop is connected to the plug-in module "Detector 1 (A-B)", clamps A or clamps B.

→ See page 183, chapter 18.1 "Wiring diagrams".

The clamp function parameters can be set in the menu "Detector 1 (A-B)" with the parameters "Mode A" or "Mode B".

→ See page 145, chapter 10.15.

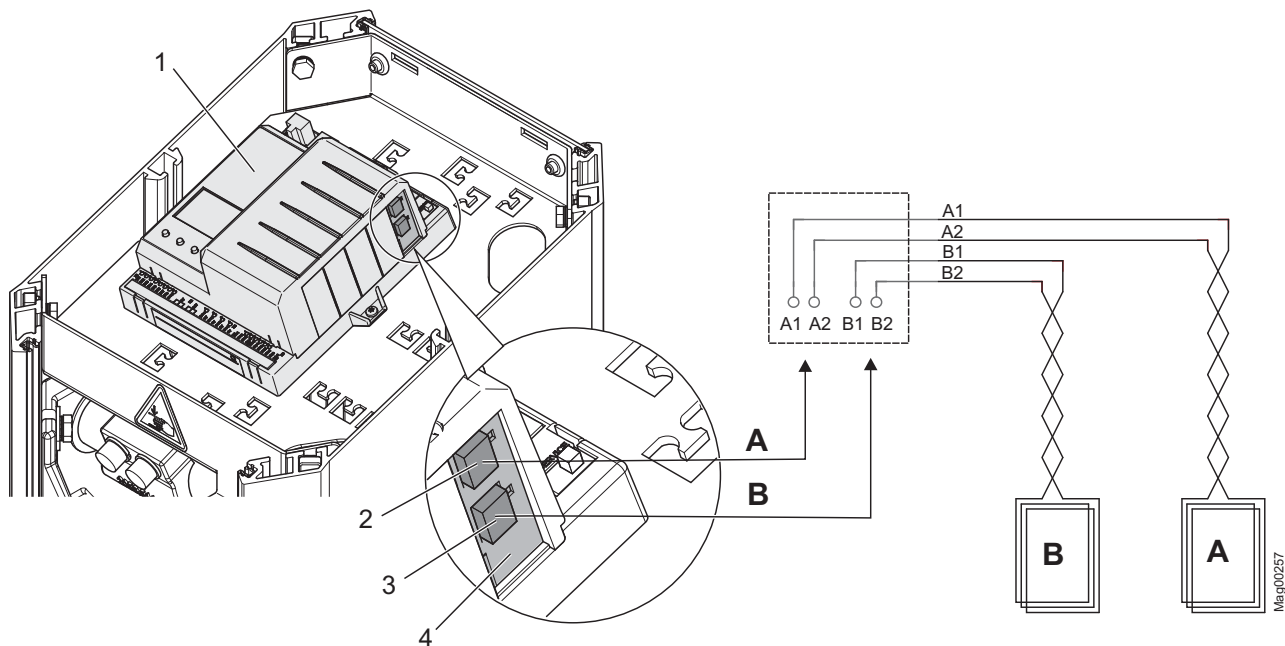

Fig. 43: Connecting safety loop

- 1 Control unit
- 2 Connection of induction loop A
- 3 Plug-in module "Detector 1 (A-B)"
- 4 Connection of induction loop B
- A Induction loop A
- B Induction loop B



NOTE!

If four induction loops must be supervised, you can connect another plug-in module with the "Detector" function into the control unit. This plug-in module registers as "Detector 2 (C-D)". To prevent mutual interference between the induction loops, we recommend using a plug-in module instead of an external detector.

9.4.4 Connect and test the safety light barriers

Connecting safety light barrier

Connect the transmitter and receiver connection lines of the safety light barriers to clamps X11 and X20.

By default, MAGNETIC installs a jumper between terminals X11 OUT and IN. When a safety light barrier is connected, the jumper must be removed.

→ See page 183, chapter 18.1 "Wiring diagrams".

Aligning the safety light barrier

The receiver is mounted at the post and the transmitter at the barrier housing. Alternatively, the receiver can also be installed to an opposite barrier housing.

1. There must not be any objects between the transmitter and receiver. The light path must be free.
2. Switch on power supply.
3. The green LEDs at the transmitter and receiver must be lit.
4. Align receiver with transmitter. If required, hold the included reflective foil in front of the receiver as setting aid. The yellow LED at the receiver lights up when aligned correctly.

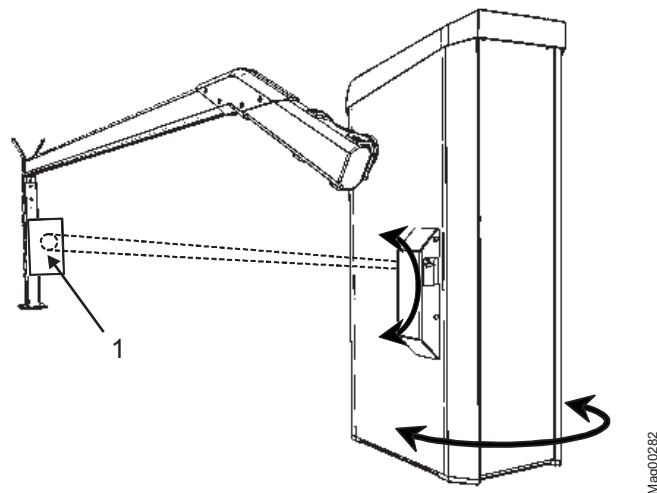

Fig. 44: Use reflective foil

1 Reflective foil

5. Slightly loosen the attachment screws from the post to align the receiver. It must be possible to turn the post.
6. Turn the post, until the yellow LED at the receiver is lit.
7. Keep reflective foil in the barrier housing.

Electrical connection

Check safety light barrier function

Perform function test by holding an object into the light path between the transmitter and receiver.

The following items must be met:

- The yellow LED at the receiver must go out.
- The barrier cannot be closed.



9.4.5 Connecting emergency opening contacts

Fire-fighter switch, emergency opening contacts, etc. are connected to the "Open high priority" input. When the signal is applied to this input, the barrier opens. While the signal is present, the barrier cannot be closed.

→ See page 91, chapter 9.4.6 "Digital inputs" and page 183, chapter 18.1 "Wiring diagrams".

9.4.6 Digital inputs

Improper parameterisation

 WARNING!	
	<p>WARNING! Risk of injury by improper parameterisation of the control unit!</p> <p>Improper parameterisation of the control unit can lead to severe injuries!</p> <p>Therefore:</p> <ul style="list-style-type: none"> – The parameterisation of the control unit may only be carried out by qualified personnel. – The electrical connection of the signal generators to the IN1 to IN8 inputs must fit the parameterisation.

Technical data

→ See page 41, chapter 4.5.



NOTE!

The digital input functions can be freely parameterised for the following versions:

- Access Pro, Access Pro L, Access Pro H, Access Select and Access Select L
- Parking Pro and Parking Select

For the remaining versions, the inputs are firmly assigned. → For output parameterisation, refer to page 106, chapter 10.

Factory setting

Clamp	Description	Function
IN1	Input 1	Open low priority
IN2	Input 2	Open low priority
IN3	Input 3	Opening with vend count
IN4	Input 4	Open high priority
IN5	Input 5	External opening loop exit
IN6	Input 6	Close
IN7	Input 7	Close
IN8	Input 8	Boom contact input

Table 26: Factory settings "Digital inputs"

The functions have different priorities towards each other. The function "Open high priority" has the highest priority (priority 1). I.e. all other functions, such as "Open low priority", "Close", etc. are ignored if the function "Open high priority" is active.

Function	Description
Open high priority	Connect fire fighter switch, emergency opening contacts, etc. to this input. This input has the highest priority. The barrier opens when +24 V DC are applied to this input. While the signal is present, the barrier cannot be closed. This input must not be used for opening loops. This input has priority over all other input functions.
Open low priority <ul style="list-style-type: none"> ■ Program modes 2, 4 to 8: Open low priority ■ Program mode 3: Close/Open 	Depending on program mode, a permanent signal or pulse is required. <ul style="list-style-type: none"> ■ Program modes 2, 4 to 8: The barrier opens when +24 V DC are applied to this input. ■ Program mode 3: The barrier changes its state with every pulse, i.e. the barrier closes or opens.
Open exit ¹⁾	This function is used for selective counting, e.g. for permanent renters of a parking space.
Opening with vend count ¹⁾	An internal vend count counts the pulses present at this input. The pulse must be present for approx. 100 to 300 ms. The reset behaviour of the vend count can be set by the "Reset behaviour" parameter.
Close	Depending on program mode, a permanent signal or pulse is required. The barrier closes when +24 V DC are applied to this input.
Close low priority	The function "Close low priority" is subordinated to all opening functions. The barrier closes when +24 V DC are applied to this input.
Inhibit opening	When +24 V DC are applied to this input, all opening commands except for the "Open high priority" and "Open exit" signals are ignored. This input function has no function in the program mode 1 to 4.
Inhibit opening loop	If the input function is active, the barrier remains closed when the opening loop is driven on.

Electrical connection

Function	Description
Inhibit signal light	Signal lights are no longer controlled when +24 V DC are applied to this input.
External opening loop entry ¹⁾	The barrier opens when +24 V DC are applied to this input. Connect external opening loops to this input.
External opening loop exit ¹⁾	The barrier opens when +24 V DC are applied to this input. Connect external opening loops to this input.
External impact detection	You can install external impact detection to the barrier arm. While no vehicle touches the barrier arm from below, the input "External impact detection" has +24 V DC applied. When the barrier arm impacts a vehicle, e.g. due to impermissible driving through of a vehicle, the +24 V DC are removed from the input "External impact detection". The barrier's behaviour in case of impact detection can be set in the "Impact settings" menu. → See page 131, chapter 10.10.7.
Boom contact input	The barrier is equipped with a boom release input in the flange. While the barrier arm is in its correct position, +24 V DC are applied to the "Boom contact input" input. When the barrier arm is moved from its position e.g. by a collision with a vehicle, the +24 V DC are removed from the "Boom contact input" input. The barrier moves into the "open" position. The boom contact must be activated in the menu "Boom contact settings". → See page 142, chapter 10.11.2
Safety device	The barrier can no longer be closed when +0 V DC are applied to this input. If the barrier is just closing when the input signal changes to 0 V and the cut off angle has not been undercut yet, the barrier will open again. This input must only be used in addition to the internal detector module or/and the safety light barriers connected to clamp X11. Only the internal safety devices are monitored.
Acknowledgement	This input is required for parallel operation. → For more information on parallel operation, see separate instructions.
Blink signal light	While +24 V DC are pending at the input, the lamps flash at 1 Hz. This input overwrites the function of the red signal lamps. You may use this function for special signalling like "Parking place assigned".

1) The parameter is only sensible for the automatic program modes 5 to 8.

Table 27: Function "Digital inputs"

9.4.7 Digital outputs and output relays

Technical data

→ See page 41, chapter 4.5.



NOTE!

The digital output functions can be freely parameterised for the following versions:

- Access Pro, Access Pro L, Access Pro H, Access Select and Access Select L
- Parking Pro and Parking Select

For the remaining versions, the outputs are firmly assigned. → For output parameterisation, refer to page 106, chapter 10.

Factory setting

Clamp	Description	Function
DO1	Digital output 1	Boom locking
DO2	Digital output 2	Pulse after passage
DO3	Digital output 3	Signal light A
DO4	Digital output 4	Signal light B
NO1	Relay 1	Open
NO2	Relay 2	Closed
NO3	Relay 3	Error
NO4/NC4	Relay 4	Loop active A
NO5/NC5	Relay 5	Loop active B
NO6/NC6	Relay 6	Signal light C

Table 28: Factory settings "Digital outputs" and "Relay outputs"

Function	Description
Error	When the control unit recognizes any "safety-relevant error" or "error", the output with this function is reactivated (Fail safe). → See page 166, chapter 13.3.
Warning	When the control unit recognizes any "Warning", the output with this function is reactivated (Fail safe).
Closed	When the barrier is closed, the output with this function is active.
Open	When the barrier is open, the output with this function is active.
Closing	While the barrier closes, the output with this function is active.
Opening	While the barrier opens, the output with this function is active.
Boom angle	This function is used to set the upper and lower angles. When the barrier arm is within this angle range, the output with this function is active. When the barrier arm is outside of the angle range set, the output is inactive. The upper and lower angle can be set for values between 0° and 90°.

Electrical connection

Function	Description
Pulse after passage ¹⁾	When a passage was detected, this output emits a counter pulse of 300 ms with this function. Passage is possible in either direction.
Sliding door pulse	This output is used to control a sliding gate. When the barrier is open, the output with this function emits a counter pulse of 300 ms with this function.
Boom contact FB (Boom contact feedback)	The barrier can optionally be equipped with a boom contact in the flange. When the boom contact triggers, the output with this function is deactivated (fail safe). The output is activated again once the boom contact is re-established and the boom is opened again entirely..
Boom locking	The barrier can optionally be equipped with a boom lock. This output serves control of the electro-mechanical boom lock at the end of the barrier arm. When the barrier is closed, the boom lock is activated via this output. If a signal is present for opening, the boom lock is removed first. The barrier opens with a short delay. The parameter "With boom locking" must be activated in the menu "Boom locking". → See page 143, chapter 10.11.3.
Parallel operation	This output can be used to operate two barriers synchronously. This output function must be activated via the menu "Master/Slave". → See page 138, chapter 10.10.11. → For information on parallel operation, see separate instructions.
Acknowledgment	This output is required for parallel operation. → For information on parallel operation, see separate instructions.
Signal light A	This output is used to control a signal light. The function of this output can be parameterised via the parameter "Signal light A", page 139, chapter 10.11.1.
Signal light B	This output is used to control a signal light. The function of this output can be parameterised via the parameter "Signal light B", page 139, chapter 10.11.1.
Signal light C	This output is used to control a signal light. The function of this output can be parameterised via the parameter "Signal light C", page 139, chapter 10.11.1.
Loop active A ¹⁾	When the induction loop A is busy, the output with this function is active.
Loop active B ¹⁾	When the induction loop B is busy, the output with this function is active.
Loop active pulse A ¹⁾	When a vehicle drives into loop A (rising flank), the output with this function emits a pulse.
Loop active pulse B ¹⁾	When a vehicle drives into loop B (rising flank), the output with this function emits a pulse.
Loop inactive pulse A ¹⁾	When a vehicle drives out of loop A (falling flank), the output with this function emits a pulse.
Loop inactive pulse B ¹⁾	When a vehicle drives out of loop B (falling flank), the output with this function emits a pulse.

Electrical connection

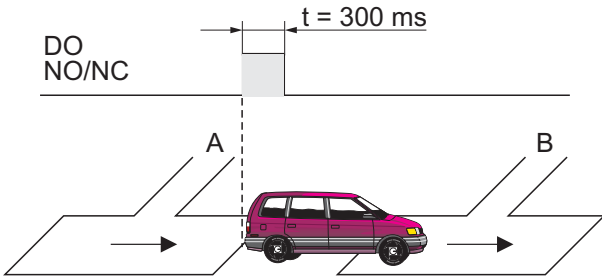
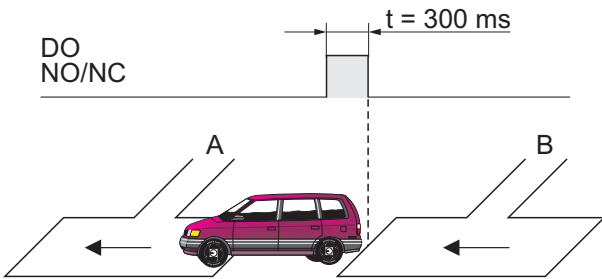
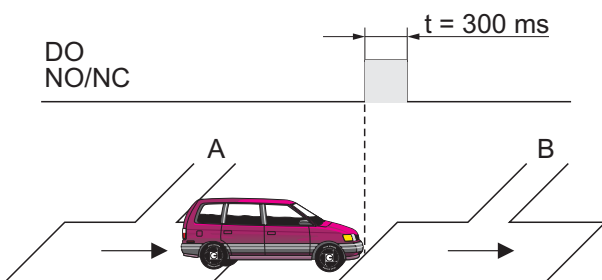
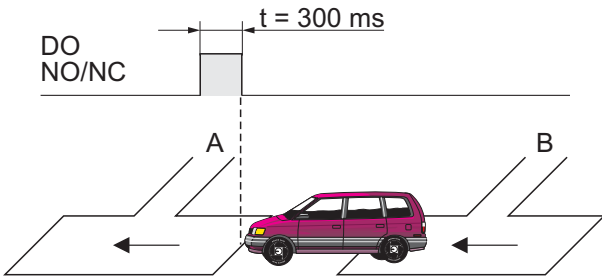
Function	Description
Direction 1 Pls A => B ¹⁾	The vehicle drives from direction A to B. When the vehicle leaves loop A in the direction of loop B, this output emits a counter pulse of 300 ms.  Mag00113
Direction 1 Pls B => A ¹⁾	The vehicle drives from direction B to A. When the vehicle leaves loop B in the direction of loop A, this output emits a counter pulse of 300 ms.  Mag000114
Direction 2 Pls A => B ¹⁾	The vehicle drives from direction A to B. When the vehicle drives on loop A in the direction of loop B, this output emits a counter pulse of 300 ms.  Mag00115
Direction 2 Pls B => A ¹⁾	The vehicle drives from direction B to A. When the vehicle drives on loop B in the direction of loop A, this output emits a counter pulse of 300 ms.  Mag00116

Electrical connection

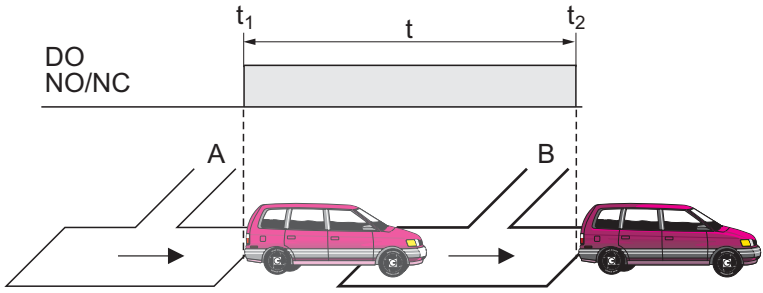
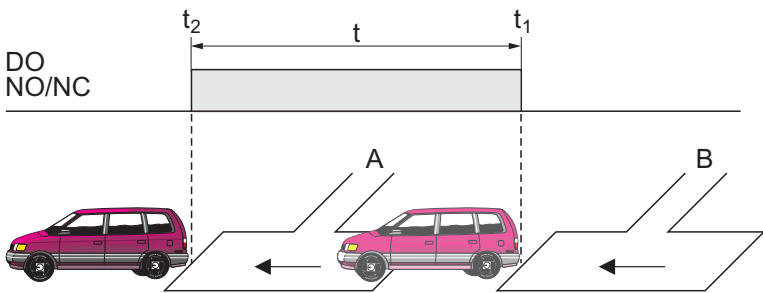
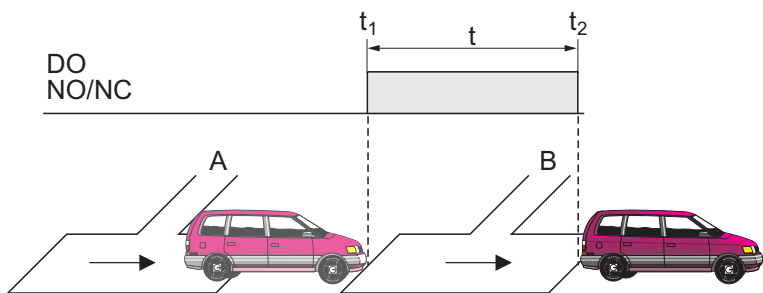
Function	Description
Direction 1 A => B ¹⁾	<p>The vehicle drives from direction A to B. When the vehicle leaves loop A, this output starts emitting a permanent signal. When the vehicle leaves loop B, this output stops the permanent signal. This function can be used, e.g. to control traffic lights.</p>  <p style="text-align: right; font-size: small;">Mag00117</p>
Direction 1 B => A ¹⁾	<p>The vehicle drives from direction B to A. When the vehicle leaves loop B, this output starts emitting a continuous signal. When the vehicle leaves loop A, this output stops the permanent signal. This function can be used, e.g. to control traffic lights.</p>  <p style="text-align: right; font-size: small;">Mag00118</p>
Direction 2 A => B ¹⁾	<p>The vehicle drives from direction A to B. When the vehicle enters loop B, this output starts emitting a continuous signal. When the vehicle leaves loop B, this output stops the permanent signal. This function can be used, e.g. to control traffic lights.</p>  <p style="text-align: right; font-size: small;">Mag00119</p>

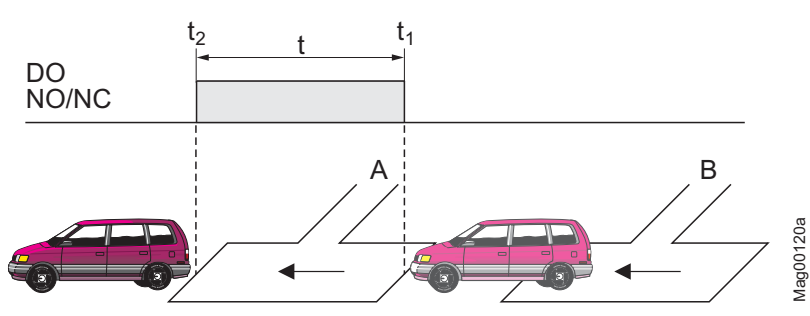
Function	Description
Direction 2 B => A ¹⁾	<p>The vehicle drives from direction B to A. When the vehicle enters loop A, this output starts emitting a continuous signal. When the vehicle leaves loop A, this output stops the permanent signal. This function can be used, e.g. to control traffic lights.</p> 
Module-Open prior ²⁾	This output function can be used to issue the command "Open high priority" of plug-in modules like "Ethernet", "Radio" or "RS485".
Module-Open ²⁾	This output function can be used to issue the command "Open" of plug-in modules like "Ethernet", "Radio" or "RS485".
Module-Close ²⁾	This output function can be used to issue the command "Close" of plug-in modules like "Ethernet", "Radio" or "RS485".

1) This function is only available with the plug-in module "Detector" plugged in.

2) This function is only available with the plug-in module "Ethernet", "Radio" or "RS485" plugged in.

Table 29: Function "Digital outputs" and "Output relay"

9.5 Checking the electrical connection

The following points have to be checked after the electrical installation of the barrier:

- Are the following electrical protective devices installed: 2-pole main switch, circuit breaker and ground fault circuit interrupter?
- Is the power cable connected to the terminal in compliance with chapter 9.3?
- Are the induction loops connected according to the wiring diagram?
- Are the safety light barriers connected according to the wiring diagram?
- Are the control lines connected according to wiring diagram?
- Have all barrier housing covers been properly assembled?



Parameterising control unit

10 Parameterising control unit

10.1 Safety

→ See also safety notes on page 20, chapter 2.6 "Occupational safety and special dangers".

Improper parameterisation

 WARNING!	
	<p>WARNING! Risk of injury by improper parameterisation of the control unit!</p> <p>Improper parameterisation of the control unit can lead to severe injuries!</p> <p>Therefore:</p> <ul style="list-style-type: none"> – The parameterisation of the control unit may only be carried out by qualified personnel or professional electricians. – The electrical connection of the signal generators to the IN1 to IN8 inputs must fit the parameterisation.

10.2 Control elements control unit

Control elements control unit MGC (Magnetic Gate Controller)

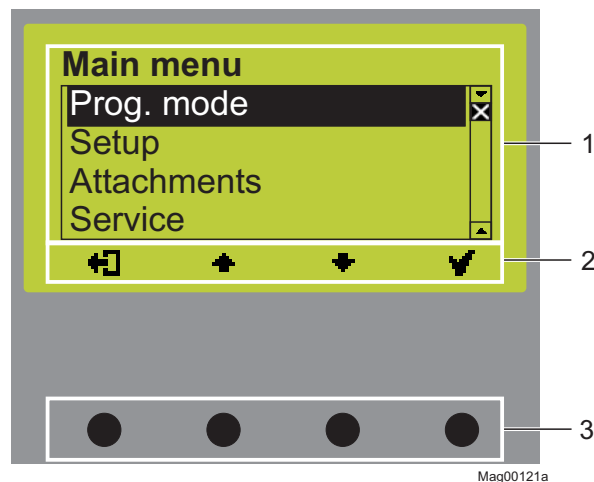

Fig. 45: Control unit elements MGC

- 1 Menu
- 2 Current function of the 4 control buttons
- 3 Control buttons

10.3 Displays on the control unit

Example "Operational view"

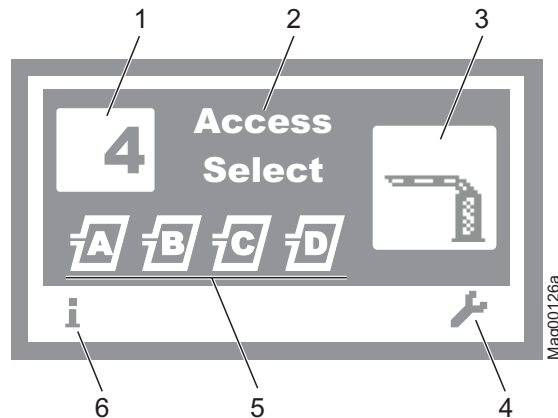

Fig. 46: Example "Operational view"

- 1 Program mode, here program mode 4
- 2 Barrier type, here type "Access Select"
- 3 Current state of the barrier, here barrier closed
- 4 Current function of the right control button, here calling menu "Main menu"
- 5 Current state of the induction loops
- 6 Current function of the left control button, here calling menu "Information"

Example "Screen change value"

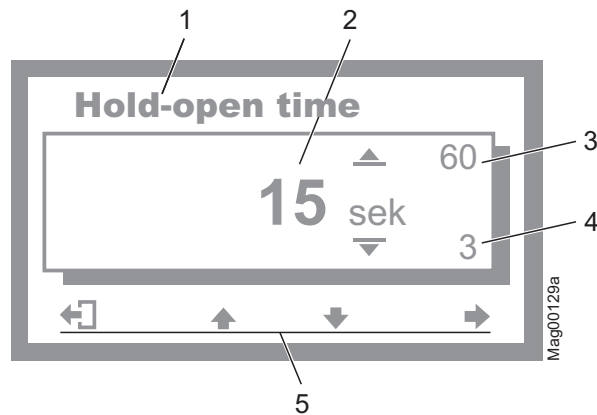

Fig. 47: Example "View - Change value"

- 1 Parameter
- 2 Current value
- 3 Possible upper value
- 4 Possible lower value
- 5 Current functions control buttons

Parameterising control unit

10.4 Symbols in the display

10.4.1 Control button functions

The control unit is equipped with 4 control buttons. The function of the control buttons change depending on the current view in the display. The current functions are displayed.













Symbols	Description
	<ul style="list-style-type: none"> ■ Call menu "Information". ■ Scroll menu "Information".
	Perform loop reconciliation
	<ul style="list-style-type: none"> ■ Call menu "Main menu" Make all settings in the menu "Main menu". ■ Menu "Information" → Menu "Detector": Perform reference of the induction loops.
	Leave current menu level. The next-higher menu level is displayed.
	<ul style="list-style-type: none"> ■ Call next-lower menu level. ■ Select desired option or desired value. When the desired option was selected, the symbol  is displayed.
	Option was selected but not yet stored
	<ul style="list-style-type: none"> ■ Within one menu level: Move cursor (market) upwards. ■ For setting value: Increase figure.
	<ul style="list-style-type: none"> ■ Within one menu level: Move cursor (market) downwards. ■ For setting value: Decrease figure.
	<ul style="list-style-type: none"> ■ Move cursor one position to the right. ■ Menu "Information" → Menu "Detector", for plug-in module "Detector (C-D)": Call view "Detector (C-D)" and switch between "Detector (A-B)" and "Detector (C-D)".
	Program mode "Service": Manually open the barrier.
	Program mode "Service": Manually close the barrier.
	<ul style="list-style-type: none"> ■ Delete error message. ■ When changing settings: Cancel changing process.

Table 30: Control button functions

10.4.2 Current state of the barrier

The barrier can have the following states:









Symbols	Description
	Barrier arm closed.
	Barrier arm open.
	Barrier arm opens.
	Closing signal was recognized. Traffic lights active. Barrier closes in 5 seconds. Time for traffic light lead is counted down.
	Barrier arm closes.
	Monitoring unit used.
	Barrier arm position unknown. "Homing" active.
	Barrier arm stopped
	An error is present.

Table 31: Current state of the barrier

Parameterising control unit

10.4.3 Current program mode



Symbols	Description
	Current program mode, here program mode 4 → For description of program modes, refer to page 113, chapter 10.7.
	Program mode "Service" → For description of program mode "Service", refer to page 123, chapter 10.7.7.

Table 32: Current program mode

10.4.4 Current state of the induction loops

The induction loops can have the following states:





Symbols	Description
	Loop A and B connected. The induction loop function is OK. If the icon flashes, the loop is occupied. If another "detector" plug-in module is connected, these induction loops are marked "C" and "D".
	The induction loop assumes the function of the safety loop. → See page 145, chapter 10.15.
	Reference is performed.
	Induction loop deactivated.
	Induction loop defective.

Table 33: Current state of the induction loops

10.4.5 Further symbols



Symbols	Description
	Wrong password entered. Access denied.
	Reset values to factory settings. Enter the password "0000" for this.













Table 34: Further symbols

10.5 Parameterising options

→ Menu setup, refer to page 191.

→ Program modes overview, refer to page 113.





















Example: Select program mode

1. The operating view is displayed. → See page 107, Fig. 46.
2. Press right control button .
3. The "Main menu" menu is displayed.
4. The "Program mode" menu is highlighted with a dark background and therefore selected. If required, select the "Program mode" menu with the two middle buttons , .
5. Confirm selection with the right control button .
6. A list with the possible program modes is displayed.
7. Select the desired program mode with the two middle buttons , .
8. Use the right button  to select the new programming mode. Your selection is marked with the symbol .
9. Use the left button  to leave the "Program mode" menu.
10. The safety prompt "Save changes?" appears.
 - If the changes are to be saved, press the right button . The new program mode is activated.
 - If the changes are not to be saved, press the left button . The previous program mode remains active.
11. The "Main menu" menu is displayed.
12. Use the left button  to leave the "Main menu" menu. The operating view is displayed.

Parameterising control unit

10.6 Parameterising values

Example: Change hold-open time

1. The operating view is displayed. → See page 107, Fig. 46.
2. Press right control button .
3. The "Main menu" menu is displayed.
4. Select the menu "Setup" with the two middle buttons  , .
5. Confirm selection with the right control button .
6. Select the menu "Delays" with the two middle buttons  , .
7. Press right control button .
8. The "Hold-open time" parameter is highlighted with a dark background and therefore selected. If required, select the "Hold-open time" parameter with the two middle buttons  , .
9. Press right control button .
10. The current hold-open time value is displayed. The cursor flashes on the first digit.
11. Use the middle buttons  ,  to set the desired digit.
12. Use the right button  to move the cursor to the right.
13. The cursor flashes on the second digit.
14. Use the middle buttons  ,  to set the desired digit.
15. Press the right button .
16. Use the left button  to leave the "Hold-open time" parameter.
17. The safety prompt "Save changes?" appears.
 - If the changes are to be saved, press the right button  .
The new hold-open time is activated.
 - If the changes are not to be saved, press the left button  .
The previous hold-open time remains active.
18. The "Delays" menu is displayed.
19. Press the left button  repeatedly until the operating view is displayed again.

10.7 Select program mode

8 program modes and the service mode are available for the MHTM™ MicroDrive barriers.

Program modes 1 to 4 are manual modes. In the manual modes, the barrier must be closed manually after a drive through.

Program modes 5 to 8 are automatic modes. In the automatic modes, the barrier closes again automatically after a vehicle drives through.

Program	Description
1	Maintained contact
2	Deadman
3	Pulse control (bistable)
4	Two-Pulse control (Open/Closed button) (Factory setting)
5	Automatic (5): with hold-open time
6	Automatic (6): with hold-open time and decoupling of the opening loop at drive through in the opposite direction
7	Automatic (7): without hold-open time
8	Automatic (8) without hold-open time and decoupling of the opening loop at drive through in the opposite direction
	Service

Table 35: Program modes

Another program mode can be selected pursuant to chapter 10.5, page 111.



NOTE!

For reasons of safety, the first barrier arm motion after program mode change is performed at slow speed.

Parameterising control unit

10.7.1 Mode 1: Maintained contact

Typical application

This mode is suitable, e.g. for parallel operation of two barriers.
→ See page 138, chapter 10.10.11 "Master/Slave".

Function

The barrier is controlled only by one switch.
When the switch is closed, the barrier closes. When the switch is opened, the barrier opens.

Supported input functions

Input function	Signal type	Supported/ Not supported
Open low priority	–	Not supported
Open low priority with vend count	–	Not supported
Open high priority (priority 1)	Pulse signal	Supported
Opening loop	–	Not supported
Close (priority 2)	Permanent signal	Supported

Table 36: Supported input functions "Maintained contact"

→ See page 98, chapter 9.4.6 "Digital inputs".

10.7.2 Mode 2: Deadman

Typical application

This mode is suitable for barriers on parking places, factory premises, etc. The barrier must be operated by a person.

Function

The barrier is operated by two buttons.

For opening the barrier, the button "open" must be pressed until the barrier is open all the way. For closing the barrier the button "close" must be pressed until the barrier is closed.

If no button is pressed, the barrier stops. If the "close" button is then pressed, the barrier opens completely first for safety reasons and then closes.

If the closing process is interrupted, only opening will be possible. A signal at the "Close" input would in this case open the barrier. If the "Close" signal is removed, the opening process is interrupted. If there is a pulse at the "Open high priority" input, the barrier opens completely.

Supported input functions

Input function	Signal type	Supported/ Not supported
Open low priority (priority 3)	Permanent signal	Supported
Open low priority with vend count	–	Not supported
Open high priority (priority 1)	Pulse signal	Supported
Opening loop	–	Not supported
Close (priority 2)	Permanent signal	Supported

Table 37: Supported input functions "Deadman"

→ See page 98, chapter 9.4.6 "Digital inputs".

Parameterising control unit

10.7.3 Mode 3: Pulse control (bistable)

Typical application

This mode is suitable for barriers on factory premises, etc. that are little frequented by vehicles. The signal generator may be, e.g. a wireless button. The barrier must be operated by a person.

Function

The barrier is opened and closed by one command unit (pulse repetition). Every pulse changes the barrier's movement direction. The pulse must be present between 100 and 300 ms.

- 1. Signal: barrier opens
- 2. Signal: barrier closes
- 3. Signal: barrier opens

etc.

If another pulse is given during closing, the barrier opens. If another pulse is given during opening, the barrier opens completely and closes afterwards for reasons of safety.

Supported input functions

Input function	Signal type	Supported/ Not supported
Open low priority (opening and closing alternatingly), (priority 2)	Pulse or permanent signal	Supported
Open low priority with vend count	–	Not supported
Open high priority (priority 1)	Pulse or permanent signal	Supported
Opening loop	–	Not supported
Close	–	Not supported

Table 38: Supported input functions "Pulse control"

→ See page 98, chapter 9.4.6 "Digital inputs".

10.7.4 Mode 4: Two-Pulse control (bistable)

Typical application

This mode is suitable for barriers on factory premises, etc. that are often frequented by vehicles. The barrier must be operated by a person.

Function

The barrier is opened and closed completely via two separate command units (signal). One pulse on the respective input is sufficient for opening or closing. The pulse must be present between 100 and 300 ms.

The input function "Open high priority" is superordinated to the input function "Close". This means that while a closing signal is applied, the barrier can be opened by the signal "Open high priority". When the opening signal is removed, the barrier closes again at once after opening completely.

Supported input functions

Input function	Signal type	Supported/ Not supported
Open low priority	Pulse or permanent signal	Supported
Open low priority with vend count	Pulse signal	Supported
Open high priority	Pulse or permanent signal	Supported
Opening loop	–	Not supported
Close	Pulse or permanent signal	Supported

Table 39: Supported input functions "Two-Pulse control"

→ See page 98, chapter 9.4.6 "Digital inputs".

Parameterising control unit

10.7.5 Automatic modes 5 to 8: Drive direction 1 – overview and differences

The automatic modes differ in their functions in drive direction 1 "Safety loop → Opening loop".

In drive direction 2 "Opening loop → Safety loop", the automatic modes are identical. →See page 122, chapter 10.7.6.

Drive direction 1: "Safety loop → Opening loop"

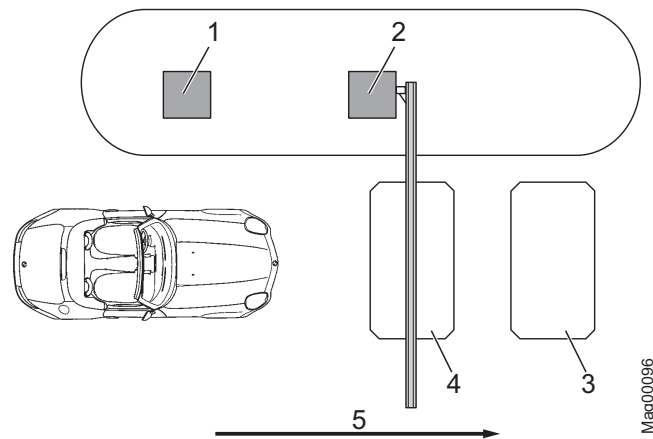

Fig. 48: Program modes 5 to 8, Passage in direction 1

- 1 Remote control, card reader, coin acceptor, etc.
- 2 Barrier
- 3 Opening loop
- 4 Safety loop
- 5 Passage in direction 1

Program mode	Hold-open time	Function Opening loop	Closing time drive backwards	Closing time without drive through
Automatic (5)	With hold-open time	The opening loop here acts as an extended safety loop.	If a vehicle drives onto the safety loop and leaves it again backwards, the barrier closes.	Barrier closes after the end of the opening time or at a closing signal.
Automatic (6)		The opening loop does not act as an extended safety loop here.		
Automatic (7)	Without hold-open time	The opening loop here acts as an extended safety loop.		Barrier closes after drive-through of the next vehicle or after the closing signal.
Automatic (8)		The opening loop does not act as an extended safety loop here.		

Table 40: Differences of automatic program modes 5 to 8, direction 1

Mode 5: Automatic (5)**Typical application**

This mode is suitable for the automatic operation of a barrier, e.g. with card readers, remote control, coin accepters and induction loops or light barriers. Passage of the barrier is possible in either direction

Function

The barrier is opened from direction 1 "Safety loop → Opening loop" with a pulse at the "Open low priority" pulse, e.g. with a card reader or coin accepter. The hold-open time that was set is also started.

When the vehicle leaves the safety loop, the hold-open time is deleted.

The barrier closes in the following cases:

- If the vehicle drives over both loops in direction 1, the barrier closes as soon as the vehicle leaves the opening loop. The opening loop here acts as an extended safety loop.
- If a vehicle drives onto the safety loop but leaves it again backwards, the barrier closes at once.
- If the vehicle drives over neither of the two loops, i.e. there is no drive through, the barrier closes after the end of the hold-open time.

→ For barriers with a safety light barrier but no safety loop installed, see page 138, chapter 10.10.10.

Mode 6: Automatic (6)**Typical application**

This mode is suitable for the automatic operation of a barrier, e.g. with card readers, remote control, coin accepters and induction loops or light barriers. Passage of the barrier is possible in either direction.

Function

The barrier is opened from direction 1 "Safety loop → Opening loop" with a pulse at the "Open low priority" pulse, e.g. with a card reader or coin accepter. The hold-open time that was set is also started.

When the vehicle leaves the safety loop, the hold-open time is deleted.

Parameterising control unit

The barrier closes in the following cases:

- If the vehicle drives over both loops in direction 1 "Safety loop → Opening loop", the barrier closes as soon as the vehicle leaves the safety loop. The opening loop here does not act as an extended safety loop.
- If a vehicle drives onto the safety loop but leaves it again backwards, the barrier closes.
- If the vehicle drives over neither of the two loops, i.e. there is no drive through, the barrier closes after the end of the hold-open time.

→ For barriers with a safety light barrier but no safety loop installed, see page 138, chapter 10.10.10.

Mode 7: Automatic (7)

Typical application

This mode is suitable for the automatic operation of a barrier, e.g. with ticket vending machines with internal logic. Passage of the barrier is possible in either direction

Function

From direction 1 "Safety loop → Opening loop", the barrier is opened by an opening signal at one of the digital opening inputs. Hold-open time is not active in this mode.

The barrier closes in the following cases:

- If the vehicle drives over both loops in direction 1, the barrier closes as soon as the vehicle leaves the opening loop. The opening loop here acts as an extended safety loop.
- If a vehicle drives onto the safety loop but leaves it again backwards, the barrier closes.
- If the vehicle does not drive onto any of the two loops, the barrier remains open until a vehicle drives through or a closing signal is given.

→ For barriers with a safety light barrier but no safety loop installed, see page 138, chapter 10.10.10.

Mode 8: Automatic (8)

Typical application

This mode is suitable for the automatic operation of a barrier, e.g. with ticket vending machines with internal logic. Passage of the barrier is possible in either direction.

Function

From direction 1 "Safety loop → Opening loop", the barrier is opened by an opening signal at one of the digital opening inputs. Hold-open time is not active in this mode.

The barrier closes in the following cases:

- If the vehicle drives over both loops in direction 1 "Safety loop → Opening loop", the barrier closes as soon as the vehicle leaves the safety loop. The opening loop here does not act as an extended safety loop.
- If a vehicle drives onto the safety loop but leaves it again backwards, the barrier closes.
- If the vehicle does not drive onto any of the two loops, the barrier remains open until a vehicle drives through or a closing signal is given.

→ For barriers with a safety light barrier but no safety loop installed, see page 138, chapter 10.10.10.

Modes 5 to 8: Automatic (5) to (8) – Supported input functions

Input function	Signal type	Supported/ Not supported
Open low priority	Pulse or permanent signal	Supported
Open low priority with vend count	Pulse signal	Supported
Open high priority	Pulse or permanent signal	Supported
Opening loop	–	Supported
Close	Pulse or permanent signal	Supported

Table 41: Supported input functions "Automatic (5) to (8)"

→ See page 98, chapter 9.4.6 "Digital inputs".

Parameterising control unit

10.7.6 Automatic Modes 5 to 8: Drive direction 2

In drive direction 2 "Opening loop → Safety loop", the automatic modes are identical.

Closing boom

⚠ WARNING!

	<p>WARNING! Danger from closing boom!</p> <p>A closing boom may cause severe or lethal injury to persons, bicyclers and cabriolet drivers!</p> <p>Therefore:</p> <ul style="list-style-type: none"> – The maximum distance between opening loop and safety loop must be not greater than max. 3.28 ft (1 m). In direction 2 "Opening loop → Safety loop", the barrier closes as soon as the vehicle leaves the opening loop. This means, if the distance is too large, the barrier closes before the car has cleared the barrier. → See page 50, chapter 7.
---	--

Drive direction 2: "Opening loop → Safety loop"

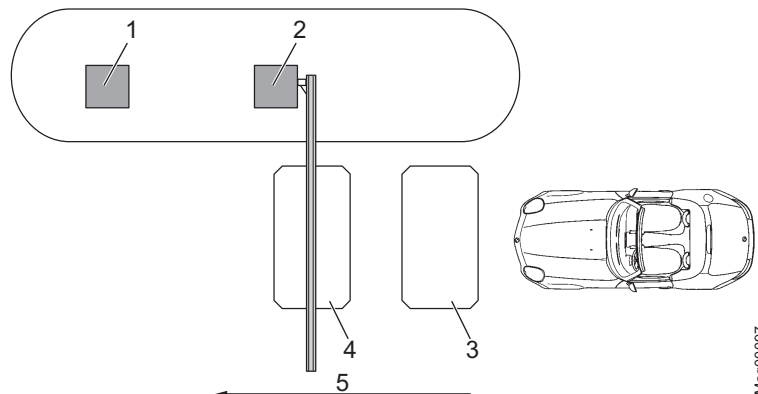

Fig. 49: Program modes 5 to 8, Passage in direction 2

- 1 Remote control, card reader, coin acceptor, etc.
- 2 Barrier
- 3 Opening loop
- 4 Safety loop
- 5 Passage in direction 2

In direction 2, the opening loop is driven on first. The barrier opens. While the opening loop or safety loop is occupied, the barrier remains open. When the vehicle has left both loops, the barrier closes.

Hold-open time is not active in drive direction 2.

When the vehicle leaves the opening loop backwards, the barrier closes at once.

10.7.7 Mode "Service"

In the "Service" mode, all opening and closing signals are ignored. The functions of safety devices like the safety loop or safety light barrier remain active for security reasons. This means that as soon as, e.g., the safety loop is occupied, the barrier cannot be closed.

Switch on Mode "Service "

Switch the "Service" switch for the "Service" mode. The LED lights red. The display backlighting flashes.

Switch off Mode "Service "

After the service work, the switch "Service" must be switched. The LED must light green.





Abb. 50: Service switch

- 1 Mode "Service" on
- 2 Mode "Service" off

Button function

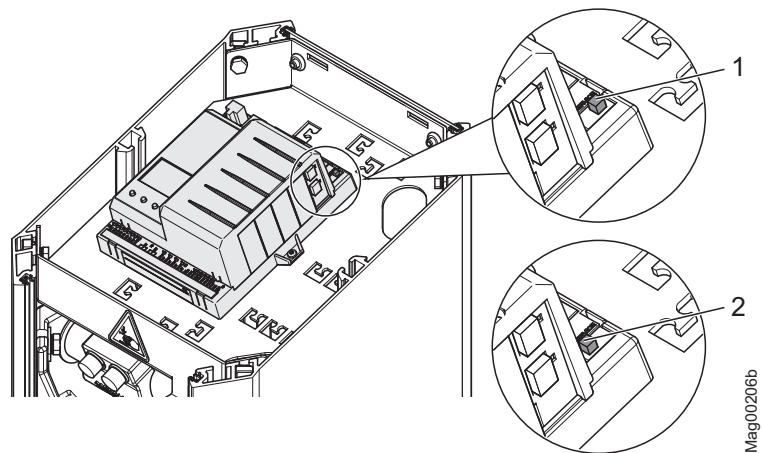
In the "Service" mode, you can control the motor with the two middle control buttons.

- Middle left button : Manually open the barrier.
- Middle right button : Manually close the barrier.



NOTE!

For reasons of safety, the first barrier arm motion after switching between program mode and service mode is performed at slow speed.

Parameterising control unit

10.8 Menu "Information" (i)

Call and navigate

1. The operating view is displayed. → See page 107, Fig. 46.
2. Press left control button **i**.
3. Use the left control button **i** to scroll within the menu.
4. The "Information" menu is can be left as follows:
 - Press the left control button **i** repeatedly until the operating view is displayed again or
 - Press right control button **+** control button.

Operating view → Information	
Parameters	Description
Error messages	Shows the currently pending errors. If no error messages are present, the menu is not displayed.
Inputs	Displays the current settings for the digital inputs IN1 to IN8
Outputs	Displays the current settings for the digital outputs DO1 to DO4 and the relay outputs NO1 to NO3 and NO/NC4 to NO/NC6.
Module info	Display of the software numbers (software #) and software versions (SW version) of the control unit and plugged-in plug-in modules.
Induction loops Detector (A-B), Detector (C-D)	Displays the current frequencies of the connected induction loops. The first plug-in module is displayed as "Detector (A-B)". The second plug-in module is displayed as "Detector (C-D)". The frequencies of induction loops A and B are displayed directly. To display the frequencies for the induction loops C and D, you have to press the button + . Use the button + you can switch the view between "Detector (A-B)" and "Detector (C-D)". → See page 145, chapter 10.15 "Menu detector 1 (A-B)".

Table 42: Menu "Information"

10.9 Program mode

→ See page 113, chapter 10.7.

10.10 Menu "Setup"

10.10.1 Barrier speed

Operating view → Main menu → Setup → Barrier speed	
Parameters	Description
Close	<p>Select the closing speed for the barrier arm.</p> <p>The closing speed can be changed for all barrier types. The option "fast" corresponds to the barrier-specific speed (100 %).</p> <p>Options</p> <ul style="list-style-type: none"> ■ slow: approx. 50 % of the maximum speed ■ medium: approx. 70 % of the maximum speed ■ fast: maximum speed (barrier-specific speed) <p>Factory setting</p> <ul style="list-style-type: none"> ■ fast
Open	<p>Select the opening speed for the barrier arm. The option "fast" corresponds to the barrier-specific speed (100 %).</p> <p>The parameter is displayed for the following boom types: Access Pro, Access Pro L, Access Pro H, Access Select and Access Select L, Parking Pro and Parking Select.</p> <p>Options</p> <ul style="list-style-type: none"> ■ slow: approx. 50 % of the maximum speed ■ medium: approx. 70 % of the maximum speed ■ fast: maximum speed (barrier-specific speed) <p>Factory setting</p> <ul style="list-style-type: none"> ■ fast

Table 43: Menu "Barrier speed"

10.10.2 Delays

Operating view → Main menu → Setup → Delays	
Parameters	Description
Hold-open time	<p>The parameter "Hold-open time" sets the hold-open time for the automatic program modes 5 and 6.</p> <p>The hold-open time is started by an opening pulse by a control unit, such as a card reader. A passage should occur during the set hold-open time. If no passage occurs during the hold-open time, the barrier closes automatically. When the vehicle drives on the safety loop, the hold-open time is deleted.</p> <p>Setting range</p> <ul style="list-style-type: none"> ■ 3 to 60 s <p>Factory setting</p> <ul style="list-style-type: none"> ■ 30 s

Parameterising control unit

Operating view → Main menu → Setup → Delays	
Parameters	Description
Close delay	<p>The barrier only closes if the set time for the closing delay is over. The timer for closing delay is started with the closing signal. With this parameter, you can also set the "Lead time" in the "Signal light" menu.</p> <p>Setting range</p> <ul style="list-style-type: none"> ■ 0 to 15 s <p>Factory setting</p> <ul style="list-style-type: none"> ■ 0 s
Light barrier delay	<p>The barrier only closes if the set time for the light barrier delay is over. The timer for light barrier delay is started with clearance of the light barrier.</p> <p>Setting range</p> <ul style="list-style-type: none"> ■ 0 to 15 s <p>Factory setting</p> <ul style="list-style-type: none"> ■ 5 s
Impact delay	<p>After the control unit has recognized that, e.g., a vehicle roof was hit by the closing barrier arm, the control unit tries to close the barrier again after the set impact delay. Impact is possible if, e.g., a user tries to drive through the barrier without permission.</p> <p>The following conditions must be met for the barrier to close after the end of the impact delay:</p> <ul style="list-style-type: none"> ■ In the "Impact Settings" menu, the parameter "Restart" must be set to "Automatic". ■ The safety devices, such as safety loop or safety light barrier, must be clear. <p>→ Also see page 131, chapter 10.10.7, menu "Impact settings".</p> <p>Setting range</p> <ul style="list-style-type: none"> ■ 5 to 30 s <p>Factory setting</p> <ul style="list-style-type: none"> ■ 5 s

Table 44: Menu "Delays"

10.10.3 Cut off angle

Operating view → Main menu → Setup → Cut off angle	
Parameters	Description
Safety loop close	<p>This parameter serves to ensure that a closed barrier can not be opened without authorisation.</p> <p>Where the barrier arm is below the set angle for "Safety loop close" during closing, signals of safety facilities like the safety loop or safety light barrier are ignored. I.e., the barrier closes completely below the angle set here.</p> <p>Setting range</p> <ul style="list-style-type: none"> ■ Access: 1...40° ■ Parking and Toll: 1...80° <p>Factory setting</p> <ul style="list-style-type: none"> ■ 10°
Light barrier	<p>Where the barrier arm is below the set angle for "Light barrier" during closing, the light barrier is ignored. I.e., the barrier closes completely below the angle set here even if the light barrier is covered.</p> <p>Setting range</p> <ul style="list-style-type: none"> ■ 1 to 40° <p>Factory setting</p> <ul style="list-style-type: none"> ■ 10°
Impact detection	<p>Where the barrier arm is below the set angle for impact detection during closing, impact detection is deactivated. I.e., the barrier closes completely below the angle set here.</p> <p>Observe the length of the barrier arm when setting the angle. The barrier arm tip height at impact detection depends on the angle set and the barrier arm length.</p> <p>Setting range</p> <ul style="list-style-type: none"> ■ 1 to 40° <p>Factory setting</p> <ul style="list-style-type: none"> ■ 10°

Table 45: Menu "Cut off angle"

10.10.4 Inputs

→ See page 98, chapter 9.4.6.

10.10.5 Outputs

→ See page 101, chapter 9.4.7.

Parameterising control unit

10.10.6 Vend count

Operating view → Main menu → Setup → Vend count	
Parameters	Description
Reset behaviour	<p>Use this parameter to set vend count reset behaviour. The function "Vend count" is available for program modes 4 to 8. An internal vend count counts the pulses present at the input with the "Opening with vend count" function. The pulses are decremented only in driving direction 1 "Safety loop → Opening loop".</p> <p>Options</p> <ul style="list-style-type: none"> ■ No counter reset (without vend count reset) ■ Time-out The vend count is set to the value "0" if the vehicle does not pass the supervision device within the set hold-open time. ■ Reset on closing The vend count is set to value "0" when a closing signal is given. ■ Time-out/Reset on closing The vend count is set to the value "0" if the event "Time-out" or the event "Reset on closing" occurs. <p>Factory setting</p> <ul style="list-style-type: none"> ■ Time-out/Reset on closing
Counter	This parameter shows the current counter reading of the vend count.
Count open loop	<p>This function is sensible for systems where the opening loop is installed farther than one vehicle length away from the safety loop. When using this function, passage is permitted in one direction only.</p> <p>Once the function is activated, passages over the opening loop are counted as impulse. The direction is not considered when decrementing the impulses.</p> <p>Options</p> <ul style="list-style-type: none"> ■ inactive ■ active <p>Factory setting</p> <ul style="list-style-type: none"> ■ inactive

Table 46: Menu "Vend count"

Example vend count with program mode "Automatic mode (5)"

This mode is suitable for the automatic operation of a barrier, e.g. with card readers, remote control, coin accepters and induction loops or light barriers. The control units and the barrier have a larger distance from each other. Instead of a hold-open time, an internal vend count is incremented and decremented. Passage of the barrier is possible in either direction.



NOTE!

In systems where no opening loop is active or the parameter "Count open loops" is active, the impulses are decremented via the safety loop only.

Drive direction 1: "Safety loop → Opening loop"

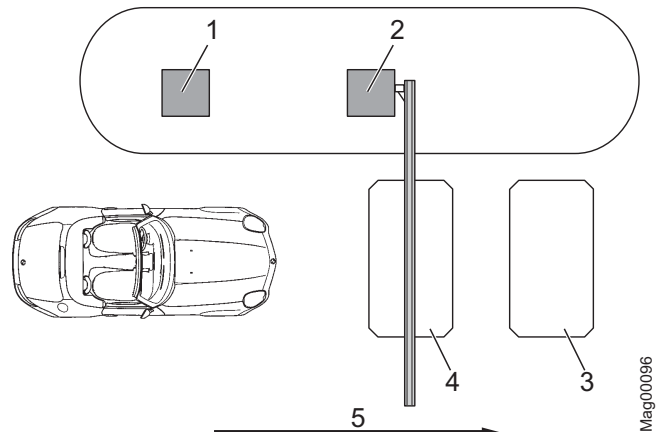

*Fig. 51: Program mode 5 with vend count,
Passage in direction 1*

- 1 Remote control, card reader, coin acceptor, etc.
- 2 Barrier
- 3 Opening loop
- 4 Safety loop exit
- 5 Passage in direction 1

The barrier is opened from direction 1 "Safety loop → Opening loop" with a pulse at the "Opening with vend count" pulse, e.g. with a card reader or coin acceptor. At the same time, an internal vend count is incremented. For the parameter "Count open loops", the option "inactive" is set.

After passage of the safety loop and the opening loop, the vend Count is decremented again. When the internal vend count reaches the value "0", the barrier is closed.

Additionally, the vend count is set to the value "0" and the barrier closed in the following cases, depending on the settings for the "Vend count" parameter:

- The vehicle does not drive over the supervision facility within the set hold-open time.
- A closing signal is assigned.

The barrier closes in the following cases:

- If the vehicle drives over both loops in direction 1, the barrier closes as soon as the vehicle leaves the opening loop. The opening loop here acts as an extended safety loop.
- If a vehicle drives onto the safety loop but leaves it again backwards, the hold-open time is deleted and the barrier closes.
- If the vehicle drives over neither of the two loops, i.e. there is no drive through, the barrier closes depending on setting of the "vend count" parameter.

Parameterising control unit

Drive direction 2: "Opening loop →
Safety loop"

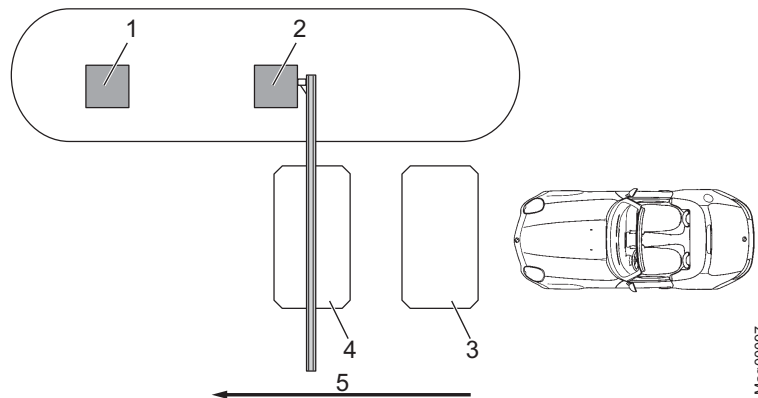

Fig. 52: Program mode 5 with pulse storage,
Passage in direction 2

- 1 Remote control, card reader, coin acceptor, etc.
- 2 Barrier
- 3 Opening loop
- 4 Safety loop exit
- 5 Passage in direction 2

In direction 2, the opening loop is driven on first. The barrier opens. While the opening loop or safety loop is occupied, the barrier remains open. When the vehicle has left both loops will the barrier close.

From drive direction 2, vend Count is not active.

When the vehicle leaves the opening loop backwards, the barrier closes at one.

Mag00097

10.10.7 Impact settings

Operating view → Main menu → Setup → Impact settings	
Parameters	Description
Impact response	<p>Select the barrier arm's impact reaction if the control unit detects an impact. → Also see page 127, chapter 10.10.3, parameter "Impact detection".</p> <p>Select the barrier boom's impact reaction if the control unit detects an impact. This setting relates to the impact detection while the barrier boom closes. If an impact is recognised during opening, the barrier boom is stopped.</p> <p>Options</p> <ul style="list-style-type: none"> ■ Open After impact detection, the barrier arm is opened completely. ■ Stop After impact detection, the barrier arm's closing movement is stopped. ■ Safe stop After impact detection, the barrier arm's closing movement is first stopped and then slightly opened. <p>Factory setting</p> <ul style="list-style-type: none"> ■ Open
Impact delay	<p>After the control unit has recognized that, e.g., a vehicle roof was hit by the closing barrier arm, the control unit tries to close the barrier again after the set impact delay. Impact is possible if, e.g., a user tries to drive through the barrier without permission.</p> <p>The following conditions must be met for the barrier to close after the end of the impact delay:</p> <ul style="list-style-type: none"> ■ In the "Restart" parameter, the option must be set to "Automatic". ■ The safety devices, such as safety loop or safety light barrier, must be clear. <p>This parameter corresponds to the parameter "Impact delay" in the "Delays" menu.</p> <p>Setting range</p> <ul style="list-style-type: none"> ■ 5 to 30 s <p>Factory setting</p> <ul style="list-style-type: none"> ■ 5 s
Restart	<p>Select behaviour of the barrier after impact recognition.</p> <p>Options</p> <ul style="list-style-type: none"> ■ Automatic The barrier boom automatically completes the started movement after the impact delay has run. ■ Signal For the barrier boom to complete the started movement, the matching signal (open/close) must be applied. <p>Factory setting</p> <ul style="list-style-type: none"> ■ Signal

Table 47: Menu "Impact settings"

Parameterising control unit

10.10.8 Start-up behaviour

Use this menu to select the start-up behaviour of the barrier according to the following events:

- after switching on voltage supply
- after return of voltage
- after reset

You can select between 7 options: The default setting is option "1".



NOTE!

The display messages "Waiting for passage" and "Waiting for release" can be confirmed with the left button of the control unit. Ensure that no persons or vehicles are present below the barrier arm. In operating modes 3 to 8, the barrier will close as soon as the message has been confirmed. In operating modes 1 and 2, a closing signal is still required after the message is confirmed.

Operating view → Main menu → Settings → Start-up behaviour (Start-up behav.)	
Option	Description
1	<p>Reference run In this option, the barrier initially performs a reference run. This means that the barrier opens completely at low speed.</p> <p>Release signal No release signal is required to close the boom.</p> <p>Closing behaviour</p> <ul style="list-style-type: none"> ■ Program modes 1 or 2: If a safety loop is installed, the barrier closes only after a vehicle has passed through and a permanent closing signal is pending. If only a safety light barrier is installed, no passage is required. The barrier closes at once when a permanent closing signal is applied. ■ Program modes 3 to 8: If a safety loop is installed, the barrier closes when the first vehicle has driven through. If only a safety light barrier is installed, the barrier closes at once when the voltage returns.

Operating view → Main menu → Settings → Start-up behaviour (Start-up behav.)

Option	Description
2	<p>Reference run In this option, the barrier initially performs a reference run. This means that the barrier opens completely at low speed.</p> <p>Release signal A release signal must be applied for the barrier to be ready for closing. The release signal can be applied even before the voltage returns. The release signal can be given by an external closing signal or by pushing the left operating button at the control unit.</p> <p>Closing behaviour</p> <ul style="list-style-type: none"> ■ Program modes 1 or 2: If a safety loop is installed, the barrier closes only after a vehicle has passed through and a permanent closing signal is pending. If only a safety light barrier is installed, no passage is required. The barrier closes at once when a permanent closing signal is applied. ■ Program modes 3 to 8: If a safety loop is installed, the barrier closes when the first vehicle has driven through. If only a safety light barrier is installed, the barrier closes at once when the voltage returns.
3	<p>Reference run In this option, the barrier initially performs a reference run. This means that the barrier opens completely at low speed.</p> <p>Release signal A release signal must be applied for the barrier to be ready for closing. If the release signal is applied before return of voltage, the release signal is ineffective. In this case, the release signal must be revoked and applied again after the barrier opens. The release signal can be given by an external closing signal or by pushing the left operating button at the control unit.</p> <p>Closing behaviour</p> <ul style="list-style-type: none"> ■ Program modes 1 or 2: If a safety loop is installed, the barrier closes only after a vehicle has passed through and a permanent closing signal is pending. If only a safety light barrier is installed, no passage is required. The barrier closes at once when a permanent closing signal is applied. ■ Program modes 3 to 8: If a safety loop is installed, the barrier closes only after the first vehicle has driven through. If only a safety light barrier is installed, the barrier closes at once when the voltage returns.

Parameterising control unit

Operating view → Main menu → Settings → Start-up behaviour (Start-up behav.)

Option	Description
4	<p>Reference run In this option, the barrier arm stops initially. The barrier will only carry out a reference run after a release signal.</p> <p>Release signal A release signal must be applied for the barrier to carry out a reference run. If the release signal is applied before return of voltage, the release signal is ineffective. In this case, the release signal must be revoked and applied again after the barrier opens. The release signal can be given by an external closing signal or by pushing the left operating button at the control unit.</p> <p>Closing behaviour</p> <ul style="list-style-type: none"> ■ Program modes 1 or 2: If a safety loop is installed, the barrier closes only after a vehicle has passed through and a permanent closing signal is pending. If only a safety light barrier is installed, no passage is required. The barrier closes at once when a permanent closing signal is applied. ■ Program modes 3 to 8: If a safety loop is installed, the barrier closes only after the first vehicle has driven through. If only a safety light barrier is installed, the barrier closes at once when the voltage returns.
5	<p>Reference run In this option, the barrier arm stops initially. The barrier will only carry out a reference run after a release signal.</p> <p>Release signal A release signal must be applied for the barrier to carry out a reference run. The release signal can be applied even before the voltage returns. The release signal can be given by an external closing signal or by pushing the left operating button at the control unit.</p> <p>Closing behaviour</p> <ul style="list-style-type: none"> ■ Program modes 1 or 2: If a safety loop is installed, the barrier closes only after a vehicle has passed through and a permanent closing signal is pending. If only a safety light barrier is installed, no passage is required. The barrier closes at once when a permanent closing signal is applied. ■ Program modes 3 to 8: If a safety loop is installed, the barrier closes only after the first vehicle has driven through. If only a safety light barrier is installed, the barrier closes at once when the voltage returns.

Operating view → Main menu → Settings → Start-up behaviour (Start-up behav.)	
Option	Description
6	<p>Reference run In this option, the barrier arm stops initially.</p> <p>Release signal The barrier carries out a reference run after the left operating button on the control unit is pressed.</p> <p>Closing behaviour</p> <ul style="list-style-type: none"> ■ Program modes 1 or 2: The barrier closes at once when a permanent closing signal is applied. ■ Program modes 3 to 8: The barrier closes at once after the barrier reference run.
7	<p>Reference run In this option, the barrier initially performs a reference run. This means that the barrier opens at low speed.</p> <p>Release signal No release signal is required to close the boom.</p> <p>Closing behaviour</p> <ul style="list-style-type: none"> ■ Program modes 1 or 2: The barrier closes at once when a permanent closing signal is applied. ■ Program modes 3 to 8: If a safety loop is installed, the barrier closes only after the first vehicle has driven through or after closing. If only a safety light barrier is installed, the barrier closes at once when the voltage returns. <p> WARNING! Danger of injury from closing arm!</p> <ul style="list-style-type: none"> ■ Sight contact to the barrier is required when the voltage is switched on again. ■ No vehicles must stand below the barrier when the closing signal is given.

Parameterising control unit

Operating view → Main menu → Settings → Start-up behaviour (Start-up behav.)	
Option	Description
8	<p>Reference run In this option, the barrier initially performs a reference run. This means that the barrier opens at low speed.</p> <p>Release signal No release signal is required to close the boom.</p> <p>Closing behaviour</p> <ul style="list-style-type: none"> ■ Program modes 1 or 2: The barrier closes at once when a permanent closing signal is applied. ■ Program modes 3 to 8: Barrier closes at once. <p> WARNING! Danger of injury from closing arm!</p> <ul style="list-style-type: none"> ■ Sight contact to the barrier is required when the voltage is switched on again. ■ No vehicles must stand below the barrier when the closing signal is given.

Table 48: Menu "Start-up behaviour"

10.10.9 Power failure

Operating view → Main menu → Setup → Power failure	
Parameters	Description
Power failure	<p>This parameter sets whether the barrier arm opens at power outage or opens or closes depending on the barrier arm position. The balancing springs must be set according to the selected option. → See page 81, chapter 8.13.</p> <p>Options</p> <ul style="list-style-type: none"> ■ Unlocked With this option, the lever system of the closed barrier is unlocked; the barrier remains closed. The boom can be opened manually. If the boom angle is less than approx. 30°, the boom will close. If the barrier arm is above an angle of approx. 35°, the barrier arm opens. The balancing springs in the lever system must be set accordingly. ■ Open In this option, the barrier arm opens at power outage. The barrier arm is moved to the locked end position with the present residual energy of the mains unit and completely opened by the balancer springs of the lever system. The balancing springs must be set correctly and the barrier arm must not be kept in the closed position by external influence. ■ Locked For this option, the barrier arm behaviour depends on the barrier arm position at power outage. When the barrier is closed, it remains closed and the lever system remains locked. Manual opening of the barrier is not possible or requires considerable application of force. If the barrier arm is below an angle of approx. 30°, the barrier arm closes. If the barrier arm is above an angle of approx. 35°, the barrier arm opens. The balancing springs in the lever system must be set accordingly. <p>Factory setting Unlocked</p>

Table 49: Menu "Power failure"

Parameterising control unit

10.10.10 Closure by light barrier

Operating view → Main menu → Settings → Closure by light barrier (light barr.)	
Parameters	Description
Closure by light barrier	<p>Use this parameter to select the closing behaviour for barriers with only one safety light barrier installed.</p> <p>If a safety loop is installed, the barrier closes only after the first vehicle has driven through in the automatic program modes 5 to 8. If only a safety light barrier is installed, the barrier will not close automatically after the first vehicle has driven through in the automatic program modes 5 to 8.</p> <p>Options</p> <ul style="list-style-type: none"> ■ Inactive In program modes 5 and 6, the barrier only closes if either a closing signal is applied or the hold-open time has passed. In program modes 7 and 8, the barrier only closes when a closing signal is applied. ■ Active In program modes 5 to 8, the barrier closes at once when a vehicle drives through the safety light barrier and after passage of the set time for the parameter "Light barrier delay". → See page 126, chapter 10.10.2. <p>Factory setting</p> <ul style="list-style-type: none"> ■ Inactive

Table 50: Menu "Closure by light barrier"

10.10.11 Master/Slave

Operating view → Main Menu → Settings → Master/Slave	
Parameters	Description
Master/Slave	<p>Activate and deactivate "Parallel operation" function. By activating the master/slave function, the corresponding inputs and outputs are automatically converted. → For information on parallel operation, see separate instructions.</p> <p>Options</p> <ul style="list-style-type: none"> ■ inactive ■ active <p>Factory setting</p> <ul style="list-style-type: none"> ■ inactive

Table 51: Menu "Master/Slave"

10.11 Menu "Attachments"

10.11.1 Signal light

The parameters "Signal mode A", "Signal mode B" and "Signal mode C" can be used to parameterise the function for the outputs "Signal light A", "Signal light B" and "Signal light C". → See page 101, Table 29.

You can connect three signal lights.

If you want to control light strips via the MAGNETIC control unit, you need to select the "Illumination strip red" option for "Signal Mode A" and "Illumination strip green" for "Signal Mode B".

Operating view → Main menu → Attachments → Signal light	
Parameters	Description
Signal mode A (continued on next page)	<p>Select function for output "Signal light A".</p> <p>The parameter "lead time" can be used to parameterise the warning lamp so that it already lights up red or flashes before closing. The lead time is the time between the closing signal and commencement of the closing procedure.</p> <p>Options</p> <ul style="list-style-type: none"> ■ Traffic light (permanent signal for red/green signal lights): <ul style="list-style-type: none"> ■ Barrier closed: Traffic light red ■ Barrier opens: Traffic light red ■ Barrier open (upper end position): Traffic light off ■ Barrier closes (without lead time)/ closing time (with lead time): Traffic light red ■ Warning signal (connection of a visual or acoustic signal/ permanent signal before and during closing of the barrier): <ul style="list-style-type: none"> ■ Barrier closed: Warning signal off ■ Barrier opens: Warning signal off ■ Barrier open (upper end position): Warning signal off ■ Barrier closes (without lead time)/ closing time (with lead time): Warning signal red ■ Flashing light (flashing light connection/ flashing signal while the barrier opens or closes): <ul style="list-style-type: none"> ■ Barrier closed: Flashing light off ■ Barrier opens: Flashing light flashes at 2 Hz ■ Barrier open (upper end position): Flashing light off ■ Barrier closes (without lead time)/ closing time (with lead time): Flashing light flashes at 2 Hz ■ Boom illumination (boom illumination connection/ permanent flashing signal except when the barrier is open): <ul style="list-style-type: none"> ■ Barrier closed: Illumination flashes at 2 Hz ■ Barrier opens: Illumination flashes at 2 Hz ■ Barrier open (upper end position): Illumination off ■ Barrier closes (without lead time)/ closing time (with lead time): Illumination flashes at 2 Hz

Parameterising control unit

Operating view → Main menu → Attachments → Signal light

Parameters	Description
Signal mode A (continued)	<ul style="list-style-type: none"> ■ Illumination strip red / Boom illumination / Flashing light <ul style="list-style-type: none"> ■ Barrier closed (lower end position): Red, permanent light ■ Barrier opens: Red flashes at 2 Hz ■ Barrier open (upper end position): Red off ■ Barrier closes (without lead time)/ closing time (with lead time): Red flashes at 2 Hz <p>Factory setting</p> <ul style="list-style-type: none"> ■ Illumination strip red
Signal mode B	<p>Select function for output "Signal light B".</p> <p>Options</p> <p>→ For the options "Traffic light", "Warning signal", "Flashing lights", "Boom illumination", see parameters "signal mode A".</p> <ul style="list-style-type: none"> ■ Illumination strip green <ul style="list-style-type: none"> ■ Barrier closed (lower end position): Green off ■ Barrier opens: Green off ■ Barrier open (upper end position): Green, permanent light ■ Barrier closes (without lead time)/ closing time (with lead time): Green off <p>Factory setting</p> <ul style="list-style-type: none"> ■ Illumination strip green
Signal mode C	<p>Select function for output "Signal light C".</p> <p>Options</p> <ul style="list-style-type: none"> ■ Traffic light (permanent signal for red/green signal lights): <ul style="list-style-type: none"> ■ Barrier closed: Traffic light red ■ Barrier opens: Traffic light red ■ Barrier open (upper end position): Traffic light off ■ Barrier closes (without lead time)/ closing time (with lead time): Traffic light red ■ Warning signal (connection of a visual or acoustic signal/ permanent signal before and during closing of the barrier): <ul style="list-style-type: none"> ■ Barrier closed: Warning signal off ■ Barrier opens: Warning signal off ■ Barrier open (upper end position): Warning signal off ■ Barrier closes (without lead time)/ closing time (with lead time): Warning signal red <p>Factory setting</p> <ul style="list-style-type: none"> ■ Warning signal

Operating view → Main menu → Attachments → Signal light	
Parameters	Description
Lead time	<p>In some application cases, it is required for reasons of safety that a warning signal for the following traffic lights up after before closing of the barrier. This warning signal must light up before the barrier closes. The warning signal is switched on with the closing signal and the lead time is started. The barrier closes only after the end of the set lead time With this parameter, you can also set the "Close delay" in the "Delays" menu.</p> <p>Setting range</p> <ul style="list-style-type: none"> ■ 0 to 15 s <p>Factory setting</p> <ul style="list-style-type: none"> ■ 0 s
Start event	<p>Select the start event from when on the signal lights should be switch.</p> <p>Options</p> <ul style="list-style-type: none"> ■ Closing signal ■ Safety loop active <p>The option "Safety loop active" is only sensible for the automatic program modes 5 to 8. If an opening signal is pending, the signal lamps are not switched.</p> <p>Factory setting</p> <ul style="list-style-type: none"> ■ Closing signal

Table 52: Menu "Signal light"

Parameterising control unit

10.11.2 Boom contact settings

The barrier can optionally be equipped with a boom contact in the flange. In the "Toll" series, the boom contact is integrated by default and performed as a "Swing Away" or "Auto Swing Away".

Operating view → Main menu → Attachments → Boom contact settings	
Parameters	Description
Inactive/Active	<p>The barrier can optionally be equipped with a boom contact in the flange. The function "Boom contact settings" is used to select the behaviour of the input function "Boom contact input" and the output function "Boom contact FB". The functions must be selected. → See page 98, chapter 9.4.6 and page 101, chapter 9.4.7.</p> <p>Options</p> <ul style="list-style-type: none"> ■ inactive The "Boom contact" is inactive. If the output function "Boom contact FB" was selected, this output is deactivated once the boom contact triggers. The input "Boom contact input" has no function in this option. ■ active The "Boom contact" is active. If "Boom contact FB" was selected for the output function, this output is deactivated once the boom contact triggers. If "Boom contact input" was selected for the input function, 24 V DC are pending at the input while the boom is resting in the flange. If the barrier arm is moved from its position, the +24 V DC are removed from the "Boom contact" input. The barrier moves into the "open" position. <p>Factory setting</p> <ul style="list-style-type: none"> ■ Inactive
Automatic closing	<p>Select signal for closing of the barrier arm after boom release.</p> <p>Options</p> <ul style="list-style-type: none"> ■ Automatic The barrier arm automatically closes after the end of the delay time. ■ Signal For the barrier arm to close, a signal must be applied to the input with the function "Close" or "Close low priority". <p>Factory setting</p> <ul style="list-style-type: none"> ■ Automatic

Operating view → Main menu → Attachments → Boom contact settings	
Parameters	Description
Closing delay	<p>The parameters are only relevant in the following cases:</p> <ul style="list-style-type: none"> ■ The barrier is a "Swing Away" or "Auto Swing Away" design. ■ In the "Close autom." parameter, the option is set to "Automatic". <p>If a car drives against a "Swing Away" barrier arm, it snaps from the flange. In the "Swing Away" version, the barrier arm must be returned to the flange manually. In the "Auto Swing Away" version, the barrier arm automatically moves into the "open" position. When the position is reached, the barrier arm is locked in the flange by springs.</p> <p>After the barrier arm has caught again, the barrier closes after the time set here.</p> <p>Setting range</p> <ul style="list-style-type: none"> ■ 0 to 10 s <p>Factory setting</p> <ul style="list-style-type: none"> ■ 10 s

Table 53: Menu "Boom contact settings"

10.11.3 Boom locking

The barrier can optionally be equipped with an electro-mechanical boom lock at the end of the barrier arm. When the barrier is closed, the boom locking is activated via the output function "Boom locking". If a signal is present for opening, the boom lock is released first. → Refer also to page 101, digital output function "Boom locking".

Operating view → Main menu → Attachments → Boom locking	
Parameters	Description
Without boom locking	Boom locking not present.
With boom locking	Boom locking present.

Table 54: Menu "Boom locking"

10.12 Menu "Service"

This menu is only intended for MAGNETIC's service and only accessible with a password.

Parameterising control unit

10.13 Menu "Information"

Operating view → Main menu → Information	
Parameters	Description
Serial No.	Displays the serial number of the control unit
Hardware Version	Displays the present hardware version
Software #	Display of the present software number
SW Version	Displays the present software version
Temperature	Displays the current temperature in the control unit

Table 55: Menu "Information"

10.14 Menu "Motor GW (Gateway)"

Operating View → Main Menu → Motor GW (Gateway)	
Parameters	Description
Software #	Displays the present software number
SW version	Displays the present software version
Motor temperature	Display of the current motor temperature
Motor-SW	Display of the present motor software

Table 56: Menu "Motor GW (Gateway)"

10.15 Menu "Detector 1 (A-B)"

This menu is used to reference the induction loops A and B.

Operating view → Main menu → → Detector 1 (A-B)	
Parameters	Description
Recalibration	Start reference of the induction loops (activate)
Mode A	<p>Select position and function of loop A.</p> <p>Options</p> <ul style="list-style-type: none"> ■ Inactive Induction loop is not present or not relevant for evaluation. ■ Active The induction loop state is put on the output with function "Loop active". Internally, the induction loop condition is not used. ■ Safety loop The induction loop assumes the function of the safety loop. ■ Opening entry The induction loop assumes the function of the opening loop on the entry lane. ■ Open exit The induction loop assumes the function of the opening loop on the exit lane. ■ Presence entry The induction loop assumes the function of the presence loop on the entry lane. ■ Presence exit The induction loop assumes the function of the presence loop on the exit lane.
Mode B	<p>Select position and function of loop B.</p> <p>→ For description, see parameter "Mode A".</p>
Sensitivity A	<p>Set the response sensitivity of the induction loop A. The response sensitivity is divided into increments.</p> <p>Factory setting</p> <ul style="list-style-type: none"> ■ 5 <p>Setting range</p> <ul style="list-style-type: none"> ■ 0...9
Sensitivity B	<p>Set the response sensitivity of the induction loop B.</p> <p>→ For description, see parameter "Sensitivity A".</p>
Frequency settings	→ See page 146, Table 58
Information	Displays information about the plug-in module "Detector 1 (A-B)". Here, the serial number (SerNo), hardware version, software # and software version of the plug-in module are displayed.

Table 57: Menu "Detector 1 (A-B)"

Parameterising control unit

Operating view → Main menu → Setup → Detector 1 (A-B) → Frequency settings	
Parameters	Description
Freq. A	Displays the currently measured frequency for induction loop A
Freq. B	Displays the currently measured frequency for induction loop B
Freq. Shift	<p>Interference influences, e.g. from external loop detectors or induction loops of barriers close by can influence the frequency of loops A and B. Use the parameter "Freq. Shift" to change the frequency values for loops A (channel A) and B (channel B) by approx. 10 % and thus reduce the influence of loops A and B.</p> <p>Options for channels A and B.</p> <ul style="list-style-type: none"> ■ High: high frequency value ■ Low: low frequency value
Ref value A	Displays the reference frequency for induction loop A
Ref value B	Displays the reference frequency for induction loop B

Table 58: Menu "Frequency settings"

10.15.1 Check the working frequency of the induction loops.

1. The operating view is displayed. → See page 107, Fig. 46.
2. Press the left control button **i** repeatedly, until the menu "Detector 1 (A-B)" is displayed.

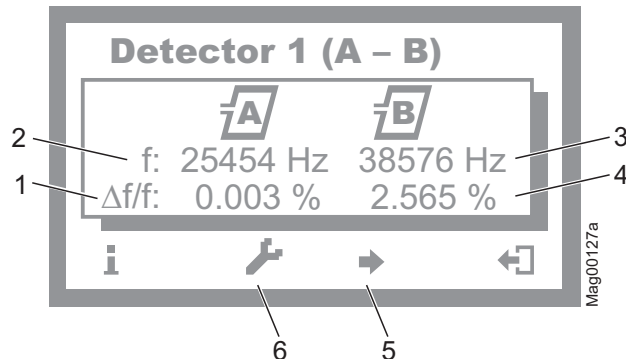

Fig. 53: Example "View – Menu Detector 1 (A-B)"

- 1 Relative frequency of induction loop A
 - 2 Currently measured frequency of induction loop A
 - 3 Currently measured frequency of induction loop B
 - 4 Relative frequency of induction loop B
 - 5 If another optional detector module is present: Switching between the two detector modules
 - 6 Recalibration of the induction loops
3. Use the right button **→** to leave the "Detector 1 (A-B)" menu. The operating view is displayed.

10.15.2 Reconciling and setting the operating frequency of the induction loop

Operating frequency requirements

The operating frequency must fulfil following requirements:

- When driving over the induction loop with a vehicle, a significant frequency increase must be measurable. Chose stage 5 or 6 for sensitivity. The relative frequency change ($\Delta f/f$) must be at least 0.1%. The higher the relative frequency increase, the higher the operating safety of the induction loop.
- The induction loops of a control unit operate alternating, and can therefore not affect each other.
However, to avoid interferences by frequency coupling from external loop detectors or other control units in the direct proximity, a frequency clearance of at least 10000 Hz must be kept between them. For this, the menu "Freq. Shift" is used to set the frequency option to "Low" or "High", or to deactivate or adjust the induction loop windings number.

Reference working frequency via the menu "Information" (i)





















1. The operating view is displayed. → See page 107, Fig. 46.
2. Press left operating button **i**.
3. Press the left control button repeatedly, until the menu "Detector 1 (A-B)" is displayed. → See page 146, Fig. 53.
4. Press second operating button from the left **↵**.
5. The barrier is referenced. The loop symbols flash during reconciliation.
6. Check working frequencies. If required, perform settings like sensitivity, etc. in the menu "Detector 1 (A-B)" in the main menu.
7. Perform one of the following steps:
 - For a "Detector" plug-in module: Use the right button **↵** to leave the "Detector 1 (A-B)" menu. The operating view is displayed.
 - For two "Detector" plug-in modules: Press the third operating button from the left **↵**. The "Detector 2 (C-D)" menu is displayed.
8. The barrier is referenced. The loop symbols flash during reconciliation.
9. Check working frequencies. If required, perform settings like sensitivity, etc. in the menu "Detector 2 (C-D)" in the main menu.
10. Use the right button **↵** to leave the "Detector 2 (C-D)" menu. The operating view is displayed.

Parameterising control unit

Frequency value of the un-assigned induction loop unstable

If the frequency value of an induction loop is unstable, this induction loop is influenced by an induction loop of another barrier or an external detector. The detector channels do not influence each other.

Depending on the loop geometry and settings of the external detector, set the menu "Freq. Shift" to "Low" or "High".

1. The operating view is displayed. → See page 107, Fig. 46.
2. Press right operating button .
3. The "Main menu" menu is displayed.
4. Select the menu "Detector 1 (A-B)" with the two middle buttons , .
5. Confirm selection with the right control button .
6. The "Detector 1 (A-B)" menu is displayed.
7. Select the menu "Frequency settings" with the two middle buttons , .
8. Confirm selection with the right control button .
9. The "Frequency settings" menu is displayed.
10. Select the menu "Freq. Shift" with the two middle buttons , .
11. Confirm selection with the right control button .
12. The "Freq. Shift" menu is displayed.
13. Select the parameter "Channel A" or "Channel B" with the two middle buttons , .
14. Confirm selection with the right control button .
15. The corresponding menu is displayed.
16. Select the option "Low" or "High" for the respective channel with the two middle buttons , .
17. Use the right button  to select the option. Your selection is marked with the symbol .
18. Use the left button  to leave the menu.
19. The safety prompt "Save changes?" appears.
 - If the changes are to be saved, press the right button .
 - If the changes are not to be saved, press the left button .
20. Press the left button  repeatedly until the operating view is displayed again.
21. Test the operating frequencies.

For another plug-in module, the menu "Detector 2 (C-D)" is displayed in the main menu. Reconciliation is performed for the induction loops A and B.

10.16 Menu "Detector 2 (C-D)"

This menu is displayed if a second plug-in module with the function "Detector" was plugged into the control unit. This menu is used to reference the induction loops C and D.

The menu "Detector 2 (C-D)" corresponds to the menu "Detector 1 (A-D)". → See page 145, chapter 10.16.

10.17 Menu "Radio control"

The "Radio control" menu is displayed when the "radio" plug-in module is plugged into one of the control unit slots.

The hand transmitters are available as 1-, 2- and 4-channel versions. With the multi-channel version, the corresponding number of barriers can be operated independently of each other with a hand transmitter.

If you want to operate the barrier via hand transmitter, manual program mode 3 or one of the automated program modes 5 to 8 must be selected.

The barrier is opened by pressing the button on the hand transmitter. The closing function depends on the selected program mode. In automatic modes 5 to 8, the barrier is closed automatically. In program mode 3, the barrier is closed by repeated pressing of the button on the hand transmitter. After pressing the button on the hand transmitter, the hand transmitter number is indicated in the display.

A radio module can manage up to 100 hand transmitters using different codes.

Operating view → Main menu → Radio control	
Parameters	Description
Number of transm. (Number of transmitter)	Display of number of hand transmitters with which the barrier can be opened
Teach in remote control	Use this parameter to pair a hand transmitter with the radio module. Options <ul style="list-style-type: none"> ■ Open high priority The button is assigned to the function "Open high priority". ■ Open The button is assigned to the function "Opening". ■ Close The button is assigned to the function "Closing".

Parameterising control unit

Operating view → Main menu → Radio control	
Parameters	Description
Delete remote control	<p>Use this parameter to revoke a pairing between a hand transmitter and the radio module.</p> <p>Options</p> <ul style="list-style-type: none"> ■ With remote control Dissolve pairing by pressing a button on the hand transmitter. ■ With number Dissolve pairing by entering the hand transmitter number. ■ Delete ALL Delete all hand transmitters. Password input is required for this.
Information	Displays information about the plug-in module "Radio". Here, the hardware version, software version and serial number (SerNo) of the plug-in module are displayed.

Table 59: Menu "Radio control"

Set hand transmitter code

The hand transmitter code is set via DIP switches in the hand transmitter. We recommend changing the DIP switches' standard settings.

1. Open hand transmitter housing. For this, press the coloured pressure point while pulling up the upper housing part at the same time.
2. Change and document the DIP switches' settings.

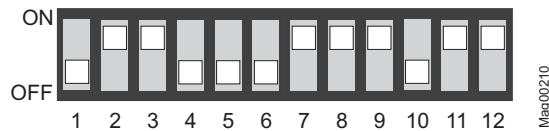





















Fig. 54: Example DIP switches settings

3. Close housing.

**Teach in remote control
example option "Close"**

1. The operating view is displayed. → See page 107, Fig. 46.
2. Press right operating button .
3. The "Main menu" menu is displayed.
4. Select the menu "Radio control" with the two middle buttons , .
5. Confirm selection with the right control button .
6. Select the parameter "Teach in remote control" with the two middle buttons , .
7. Confirm selection with the right control button .
8. Select the parameter "Close" with the two middle buttons , .
9. The message "Press button" appears.
10. Press the button on the hand transmitter. For the 2-channel hand transmitter, the corresponding channel is paired with the radio module.
11. The message "Successful" appears on the display. The number for the parameter "Number of transmitter" is increased by one.
12. Press the left button  repeatedly until the operating view is displayed again.

Delete remote control

1. The operating view is displayed. → See page 107, Fig. 46.
2. Press right operating button .
3. The "Main menu" menu is displayed.
4. Select the menu "Radio control FM" with the two middle buttons , .
5. Confirm selection with the right control button .
6. Select the parameter "delete remote control" with the two middle buttons , .
7. Confirm selection with the right control button .
8. The options "With remote control" and "With number" are displayed.
9. Select an option with the two middle buttons , .
10. Confirm selection with the right control button .

Option "with remote control"





The option "With remote control" was selected

1. The message "press button" appears.
2. Press the button on the hand transmitter.
3. The message "Successful" appears. The number for the parameter "Number transmitter" is decreased by one.
4. Press the left button  repeatedly until the operating view is displayed again.

Parameterising control unit

Option "with number"

The option "With number" was selected

1. Enter hand transmitter number.
2. Use the left button  to leave the menu.
3. The safety prompt "Save changes?" appears.
 - If the hand transmitter is to be deleted, press the right button .
 - If the hand transmitter is to be deleted, press the left button .
4. The "Delete remote control" menu is displayed.
5. Press the left button  repeatedly until the operating view is displayed again.

Option "Delete ALL"

The option "Delete ALL" was selected

1. Enter the service password.
2. Confirm input with the right control button .
3. The message "Successful" appears. All hand transmitters were deleted.











NOTE!

If a hand transmitter is deleted, the memory slot used is released. The sequence does not change by deletion. Teaching in new hand transmitters will first fill the gaps and only then continue numbering.

10.18 Factory Settings

Reset parameters

This menu can be used to reset the parameters to factory settings.



1. The operating view is displayed. → See page 107, Fig. 46
2. Press right operating button .
3. The "Main menu" menu is displayed.
4. Select the menu "Factory Settings" with the two middle buttons , .
5. Confirm selection with the right control button .
6. Enter password "0 0 0 0".
7. Confirm password with the right control button .
8. The message "Reset to factory settings" appears.
9. Press right operating button .
10. The safety prompt "Save changes?" appears.
 - If the changes are to be saved, press the right button . The current settings are reset to factory settings. Restart is performed
 - If the changes are not to be saved, press the left button .
11. Press the left button  repeatedly until the operating view is displayed again.

11 Start-up and operation



11.1 Safety

→ See also safety notes on page 20, chapter 2.6 "Occupational safety and special dangers".

General

 WARNING!	
	<p>WARNING! Danger by inappropriate start-up and operation!</p> <p>Inappropriate start-up and operation can cause severe or lethal injuries.</p> <p>Therefore:</p> <ul style="list-style-type: none"> – Commissioning and operation must be performed by specialists or electronics specialists. – Always observe the radius of action of the barrier arm. – Prior to start of works ensure that all housing covers are correctly mounted.

Wind forces over 10 Beaufort

 WARNING!	
	<p>WARNING! Risk of injury from breaking off barrier arms in case of high wind speeds!</p> <p>In case of wind speeds exceeding 10 Beaufort, the barrier arm may break off from the wind load and cause severe injuries.</p> <p>Therefore observe in case of storm warnings above 10 Beaufort:</p> <ul style="list-style-type: none"> – Disassemble barrier arm or secure it with suitable measures. – Stop operating the barrier system.

Personal protective equipment

The following must be worn during start-up:

- Work clothes
- Protective gloves
- Safety shoes
- Protective helmet.

11.2 Commissioning

Check before to initial start-up

The following inspections must be performed prior to initial start-up:

- Check electrical connections.
- Check barrier arm position.
- Check balancing springs in the lever system and adjust if required.

Inspection during the first start-up

The following inspections must be performed prior to first start-up:

- Check program mode. → See page 113, chapter 10.7.
- Check parameterisation in connection with wiring.
- Testing and setting the operating frequency of the induction loops. → See page 146, chapter 10.15.1.
- Check the function of the barrier, induction loops, safety light barriers and the signalling devices.

11.3 Switching on and off the barrier

NOTICE!



NOTICE!

A too early mains voltage power up after a shut down can result in damage of the equipment!

Therefore:

- Wait for at least 10 seconds after shutting off the mains voltage before you switch the mains voltage on again.

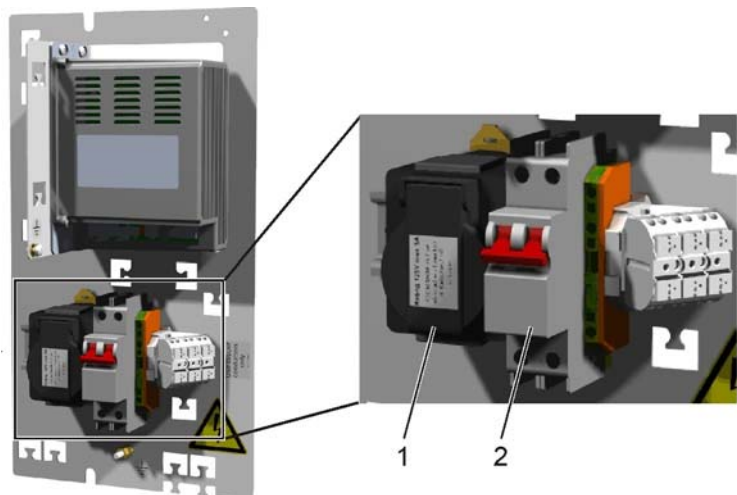

Fig. 55: Switching on and off the barrier

- 1 Service socket (WARNING: Service socket is live, also when mains switch is switched off.)
- 2 Double pole mains switch

Start-up and operation

Switching on

1. Remove the barrier housing hood.
2. Remove the barrier housing door.
3. Switch on the barrier via the double pole mains switch.
4. Depending on the settings in the "Start-up behaviour" menu, the barrier arm slowly moves into the top end position (homing run) or stops.
5. Mount the door.
6. Attach and lock the hood.

Switching off

1. Remove the barrier housing hood.
2. Remove the barrier housing door.
3. Switch off the barrier via the double pole mains switch.
4. Depending on the settings of the lever system's balancing spring and the settings in the menu "Start-up behaviour", the barrier arm opens or closes. → See page 81, chapter 8.13 and page 137, chapter 10.10.9.
5. Mount the door.
6. Attach and lock the hood.

11.4 Putting the barrier temporarily out of operation

High wind speeds

⚠ WARNING!	
	<p>WARNING! Risk of injury from barrier arm in case of high wind speeds!</p> <p>The barrier arm is no longer securely locked with the mains voltage off. At high wind speeds, the barrier arm can be pressed from its end position. The moving barrier arm can severely injure a person.</p> <p>Therefore:</p> <ul style="list-style-type: none">– Keep supplying the barrier with mains voltage.– Remove the barrier arm if necessary.

NOTICE!	
	<p>NOTICE! Possible damage to the equipment by condensed water when mains voltage is switched off!</p> <p>Therefore:</p> <ul style="list-style-type: none">– Keep supplying the barrier with mains voltage.

If the barrier is put out of operation for a longer period, proceed as follows:



1. Switch off barrier. → See page 155, chapter 11.3.
2. Remove the barrier arm if necessary. → See page 173, chapter 14.2.
3. Protect the barrier from corrosion and contamination.
4. Switch on barrier. → See page 155, chapter 11.3.

12 Maintenance

12.1 Safety

→ See also safety notes on page 20, chapter 2.6 "Occupational safety and special dangers".

General

 WARNING!	
	<p>WARNING! Danger by inappropriate maintenance!</p> <p>Inappropriate start-up and operation can cause severe or lethal injuries.</p> <p>Therefore:</p> <ul style="list-style-type: none"> – All maintenance work must be performed by specialists or electrical specialists. – Prior to work, ensure that there is sufficient assembly space. – Pay attention to tidiness and cleanness at the assembly site! Loosely stacked or lying around components and tools are accident sources. – After completion of maintenance work, ensure that all covers are correctly mounted. – Wear protective helmet.

Personal protective equipment

The following must be worn during maintenance work:

- Work clothes
- Protective gloves
- Safety shoes
- Protective helmet.

Maintenance book

In barriers where personal traffic cannot be excluded, a maintenance book must be maintained.

In any other barriers, maintenance of a test book is not mandatory. However, we recommend keeping a test book in such barriers as well, to properly document all maintenance work.

12.2 Cleaning

Aggressive cleaning aids and substances

The cleaning interval essentially depends on the environmental conditions and the climate.

NOTICE!



NOTICE!
Unit damage possible!

Aggressive detergents and consumables may damage or destroy components, electric cables, or the coating of the barrier.

Therefore:

- Do not use cleaning agents with aggressive ingredients.

Carrying out cleaning work:

1. Switch off power supply and secure against restarting.



DANGER!

Mortal danger by electric voltage!

- Keep moisture and dust away from live parts. Moisture or dust may cause a short circuit.
 - Never clean the barrier housing and barrier arm with vapour or pressure-jet cleaners.
2. Remove contamination from the outside of the barrier housing properly using water with washing-up liquid and a square of cloth. Do not bring control units and electrical components in contact with moisture.
 3. Remove dust inside the housing with a vacuum cleaner.
 4. After cleaning work, check that all previously opened covers are closed again and that all safety equipment functions correctly.

Maintenance

12.3 Maintenance schedule

The following describes the maintenance work that is necessary for optimal, trouble-free operation. Maintenance intervals must be observed.

If increased wear of individual components or functional groups is revealed during regular inspections, the operator must reduce the required maintenance intervals on the basis of the actual signs of wear.

In case of queries regarding the maintenance work and intervals: contact the manufacturer (for service address, refer to page 2).

Interval	Maintenance work	To be carried out by
Monthly	Visual inspection of the housing, inside and out, for damage and corrosion. Clean the housing and repair paint damage as necessary. Remove corrosion damage.	Specialist
	Visual inspection of foundation anchors, U-profiles and mounting material for corrosion. Remove corrosion damage.	Specialist
	Visual inspection of the barrier arm for damage and corrosion. Clean the barrier arm and repair paint damage as necessary. Remove corrosion damage.	Specialist
	Visual inspection of additional parts, light barrier posts and the pendulum support for damage and corrosion. If necessary, clean additional parts, light barrier posts and pendulum support and repair paint damage. Remove corrosion damage.	Specialist
	Where they exist, inspect lenses and mirrors of the light barriers.	Specialist
Every 6 months	Check function of the ground fault circuit interrupter (GFCI).	Electrical specialist
	Check the barrier casing fastening screws for tight fit. If required, tighten the screws.	Specialist
	Check the screws of the additional parts, pendulum support and light barrier post for tight fit. If required, tighten the screws.	Specialist
	Check the barrier arm and flange fastening screws for tight fit. If required, tighten the screws.	Specialist

Interval	Maintenance work	To be carried out by
Every 12 months	Check the barrier's mechanics.	MHTM MicroDrive service specialist
	Check the spring setting of the lever system.	
	Check barrier arm position.	
	Visual inspection of the induction loops and the roadway for damage.	
	Check the induction loops' function. → See page 146.	
	Check the induction loops. Measure the contact resistance, insulation resistance, and inductance of the induction loops. → See page 63.	
	Where they exist, check the function of additional safety equipment, such as light barriers.	
	Check the barrier's function.	
	Check the parameter settings. → See page 106 et seq.	
	Check the barrier's locking in the position "Closed".	
	Check the advanced warning on barriers with the active function "Traffic lights lead".	
	Check electric cables for damages.	
	Check if all electrical connections are firm.	
	Check signs and labels for legibility.	
Check foundation fastening.		
The cleaning interval depends on the environmental conditions and the climate.	Cleaning barrier arm.	Specialist
	Clean barrier housing from the inside.	Specialist

Table 60: Maintenance schedule

13 Malfunctions



This chapter describes possible causes of malfunctions and trouble shooting tasks.

Contact your dealer in case of malfunctions that cannot be repaired by means of the following information. Procure spare parts from your dealer or directly from the manufacturer. For the address, see invoice, delivery note or the reverse of these instructions.



13.1 Safety

→ See also safety notes on page 20, chapter 2.6 "Occupational safety and special dangers".

General

 WARNING!	
	<p>WARNING! Danger of injury from inappropriate troubleshooting!</p> <p>Inappropriate troubleshooting can cause severe or lethal injuries.</p> <p>Therefore:</p> <ul style="list-style-type: none"> – All troubleshooting work must be performed by specialists or electronics specialists. – Observe possible movements of the barrier arm. A defective control unit may lead to inadvertent movement of the barrier arm. – Prior to work, ensure that there is sufficient assembly space. – Pay attention to tidiness and cleanness at the assembly site! Loosely stacked or lying around components and tools are accident sources. – Deactivate the barrier if any components are damaged, e.g. the barrier arm. – After completion of troubleshooting, ensure that all covers are correctly mounted.

Danger of injury after lightning strike

 WARNING!	
	<p>WARNING! Danger of injury from total outage or barrier malfunction after lightning has hit the barrier!</p> <p>If the barrier is struck by lightning, this may lead to total outage or malfunction of the barrier. The malfunction may cause unexpected barrier behaviour and thus lead to serious injury!</p> <p>Therefore:</p> <ul style="list-style-type: none"> – If the barrier is struck by lightning, have an electrician check the barrier for damage and proper function. Repair barrier if required. – Observe possible movements of the barrier arm. Defective control may lead to inadvertent movement of the barrier arm.

13.2 Malfunction table – barrier malfunctions

→ For requirements to the MHTM MicroDrive service specialist, see page 19, chapter 2.4.1.

Malfunction	Possible cause	Corrective action	To be carried out by
Barrier out of operation. The message "Safety device missing" appears on the display.	No safety loop is connected to the plug-in module "Detector" and no safety light barrier to the clamps X11 and X20.	Connect either the safety loop or safety light barrier. → See page 183, chapter 18.1.	Electrical specialist
	The safety device is defective.	Replace safety device.	
Barrier does not open.	The safety device is defective.	Replace safety device.	Electrical specialist
	Error present. The corresponding error message is displayed.	Depending on error message, check components, wiring, etc.	MHTM MicroDrive service specialist
	Power supply is present. Control unit display does not light up.	Control unit defective. Replace the control unit. Contact service.	MHTM MicroDrive service specialist
	Loop interference due to external loop detectors or other barriers in the proximity.	Check the operating frequency of the loops and adjust if necessary	MHTM MicroDrive service specialist
	Closing signal is active.	Remove closing signal	Electrical specialist

Malfuncions

Malfuncion	Possible cause	Corrective action	To be carried out by
Barrier does not open completely.	Spring tension in the balancing springs of the lever system set too weakly for the barrier arm weight.	Adjust balancing springs. → See page 81, chapter 8.13.	MHTM MicroDrive service specialist
Barrier does not close immediately after through traffic, but only after the hold-open time.	Opening signal is active for too long.	Shorten opening signal to max. 1 second.	Electrical specialist
	Safety loop does not respond.	Check the response sensitivity of the safety loop. Adjust setting if necessary.	MHTM MicroDrive service specialist
Barrier does not close.	Opening command is active.	Cancel the opening command.	Electrical specialist
	Induction loop reports engaged, although no vehicles are present.	<ul style="list-style-type: none"> ■ Check and if necessary adjust loop frequencies. ■ Measure loops. Insulation resistance: > 1 Mohm contact resistance: 0.8 to 2.5 ohm Replace loop if the measured values differ from the specified values.	MHTM MicroDrive service specialist
	Wire bridge between terminals X11 IN and OUT missing.	If no safety light barrier is connected, a wire bridge must be installed between the clamps X11 OUT and IN. → See page 183, chapter 18.1.	MHTM MicroDrive service specialist
	Message "Boom contact active": At the "Boom contact" input, boom ejection was detected.	<ul style="list-style-type: none"> ■ Barrier with Swing Away and automatic return: Wait for delay. 	Operator
<ul style="list-style-type: none"> ■ Barrier with Swing Away and manual return: Put barrier arm in the original position manually. 		Operator	
<ul style="list-style-type: none"> ■ Barrier without Swing Away: Replace the barrier arm 		MHTM MicroDrive service specialist	
Barrier does not close. The message "Waiting for release" appears on the display.	The message appears after the voltage supply is switched on, after voltage returns and after reset.	The release signal can be given by an external closing signal or by pushing the left operating button at the control unit. → See page 132, chapter 10.10.8.	Operator

Malfunctions

Malfunction	Possible cause	Corrective action	To be carried out by
Barrier does not close. The message "Waiting for authorization" appears on the display.	The message appears after the voltage supply is switched on, after voltage returns and after reset.	<ul style="list-style-type: none"> ■ The barrier closes once a vehicle passes. → See page 132, chapter 10.10.8. ■ Confirm message via the left button at the control device. 	Operator
Barrier does not close completely.	Spring tension in the balancing springs of the lever system set too strongly for the barrier arm weight.	Adjust balancing springs. → See page 81, chapter 8.13.	MHTM MicroDrive service specialist
	Impact was recognized.	Wait several seconds, barrier closes if no obstacle is below the barrier arm anymore.	–
Barrier does not close. The display shows: 	Loop not connected.	Connect loop	MHTM MicroDrive service specialist
	Detector mode incorrectly parameterised.	Check the parameters of the detector module and correct it if necessary. → See page 145, chapter 10.15.	
	Loop defective.	Replace loop.	
	Transfer resistance at the terminals	Cut connecting leads, strip and connect them again without end sleeves.	
Barrier closes, although a vehicle is standing on the safety loop.	"Safety loop" not selected for "Mode A" or "Mode B" in the menu "Detector 1 (A-B)".	Select option "Safety loop".	MHTM MicroDrive service specialist
	Cut off angle incorrectly parameterised.	Check and adjust the cut off angle.	
	Too low trigger sensitivity set for the loop.	Check the response sensitivity of the loop and adjust if necessary.	
	Inappropriate loop geometry is installed.	Install an appropriate loop geometry.	
	Loop interference due to external loop detectors or other barriers in the proximity.	Check the operating frequency of the loops and adjust if necessary	
	Safety light barrier connected incorrectly or defective.	Check safety light barrier function.	
	User misbehaviour e.g. driving into closing barrier, or following behind another vehicle.	<ul style="list-style-type: none"> ■ Retrofit signal light, such as red/green signal light and parameterise lead time. ■ Upgrade signs. 	Operator

Table 61: Malfunction table – Barrier

Malfuncions

13.3 Warning and interference messages on the display

The control unit display indicates the corresponding warning or error message in case of an error.

Warning messages

Warning messages serve as notice. The barrier continues to operate normally.

Error messages

In case of error messages, the barrier is shut down. For the barrier to be started up again the error must be removed by an MHTM MicroDrive service specialist and a reset performed pursuant to chapter 13.4.

→ For requirements to the MHTM MicroDrive service specialist, see page 19, chapter 2.4.

13.3.1 Warning and interference messages – Logic control (Control unit)

Number	Description	Possible cause	Corrective action
FF01 WARNING	Error barrier mechanics	The first closing motion could not be performed completely.	<ul style="list-style-type: none"> ■ If required, remove obstacle below the barrier arm. ■ Check barrier mechanics. ■ Check the spring setting of the balancing springs.
FF02 WARNING	Detector monitoring signal	Communication between logic control and detector module impaired.	<ul style="list-style-type: none"> ■ Perform reset. → See page 170, chapter 13.4. ■ Check plug contacts. ■ Clean plug contacts with spirit. Observe ESD provisions. ■ Replace the control unit.
FF03 ERROR	Monitoring device is missing	No monitoring loop is connected to the detector module and no safety light barrier to the clamps X11 and X20.	Connect either the safety loop or safety light barrier. → See page 183, chapter 18.1.
		Safety device defective	Replace safety device.
		Sensitivity settings in the "Detector" menu too low. Not all vehicles are recognised.	Change sensitivity. → See page 145, chapter 10.15.
FF04 ERROR	Barrier too fast	Spring tension in the balancing springs of the lever system set too weakly for the barrier arm weight.	<ul style="list-style-type: none"> ■ Adjust balancing springs. → See page 81, chapter 8.13. ■ Contact service if required.

Malfuncions

Number	Description	Possible cause	Corrective action
FF05 WARNING	Book contact / Swing-sway active	At the "Boom contact" input, boom ejection was detected.	<ul style="list-style-type: none"> ■ Barrier with SwingAway and automatic return: Wait for delay. ■ Barrier with SwingAway and automatic return: Put barrier arm in the original position manually. ■ Barriers without Swing Away: Replace the barrier arm ■ If required, choose the option "Off" in the "Boom contact settings" menu. ■ Verify cables
FF06 WARNING	Vandalism	The barrier arm was either lifted from the lower end position or stopped when closing.	In the closed position, check that the lever system latches.
FF30 WARNING	Impact detection	Impact was recognised by the input "external impact contact".	<ul style="list-style-type: none"> ■ Wait for a few seconds. The barrier closes if no obstacle is below the barrier arm anymore. ■ When no obstacle is present below the barrier arm, check input, e.g. contact strip.
3120 ERROR	Mains voltage fluctuations	Short-term mains outage was recognised	<ul style="list-style-type: none"> ■ Check supply voltage/mains quality
5530 ERROR	EEPROM checksum	Check sum of the parameter incorrect	<ul style="list-style-type: none"> ■ Re-set parameters to factory defaults. → See page 153, chapter 10.18. ■ Contact service if required.
6000 ERROR	Module update error	A firmware update was not performed correctly.	<ul style="list-style-type: none"> ■ Restart the control unit ■ If the error continues to be present, perform the update again via the service module.
6102 ERROR	Software error system bus	Within the control, an error is pending in communication.	<ul style="list-style-type: none"> ■ Check FW versions of all plug-in modules. If required, perform update via service module. ■ If all FW versions are up to date, contact service.
6105 ERROR	Error during homing	The barrier could not perform any reference run.	<ul style="list-style-type: none"> ■ Check motor communication. ■ Check mechanics. ■ Perform reset. → See page 170, chapter 13.4.

Malfuncions

Number	Description	Possible cause	Corrective action
8130 WARNING	Note monitoring	Communication with a plug module was interrupted.	<ul style="list-style-type: none"> ■ Check if all plugged modules are listed in the main menu. ■ Perform reset. → See page 170, chapter 13.4. ■ Contact service if required.

Table 62: Warning and interference messages – logic control (control unit)

13.3.2 Warning and interference messages – Motor GW

Number	Description	Possible cause	Corrective action
2220 WARNING	Overcurrent	Overcurrent was recognised	<ul style="list-style-type: none"> ■ Warning may appear in connection with impact. ■ If no impact took place, check the cables. ■ Contact service if required.
3211 WARNING	Overvoltage	Overvoltage was recognised	<ul style="list-style-type: none"> ■ Warning may appear in connection with impact. ■ If no impact took place, check the cables. ■ Contact service if required.
3221 WARNING	Undervoltage	Undervoltage was recognised	<ul style="list-style-type: none"> ■ Warning may appear in connection with impact. ■ If no impact took place, check the cables. ■ Contact service if required.
4210 WARNING	Overtemperature	A high temperature was recognised.	<ul style="list-style-type: none"> ■ Check motor temperature via display. The temperature must be below 100 °C. → See page 144, chapter 10.14. ■ Contact service if required.
4220 WARNING	Derating error	Motor power intake is reduced to avoid further temperature increase.	<ul style="list-style-type: none"> ■ Remove impermissible attachments ■ Check the spring setting of the balancing springs. ■ Reduce speed of the barrier arm. ■ Contact service if required.

Number	Description	Possible cause	Corrective action
FF30 WARNING	Impact detection	Impact was recognised.	<ul style="list-style-type: none"> ■ Check safety devices. ■ Adjust menu "Cut off angle" → See page 127, chapter 10.10.3. ■ If there was no impact on an obstacle/vehicle, check the spring settings of the balancing springs and mechanics.
7510 ERROR	Motor communications error	Communication between motor and control impaired or interrupted	<ul style="list-style-type: none"> ■ Verify cables ■ Contact service if required.
FF32 ERROR	HW-Enable-Test failed	–	Contact service.
FF33 ERROR	LS-Test failed	Safety light barrier test failed	Check light barrier and light barrier connection.
FF37 ERROR	Motor update failed	An error occurred when updating the software	<ul style="list-style-type: none"> ■ Perform reset. → See page 170, chapter 13.4. ■ Contact service if required.
FF3A WARNING	Motor update was performed	Message serves information purposes	–

Table 63: Warning and interference messages – Motor GW

13.3.3 Warning and interference messages – Detector

Number	Description	Possible cause	Corrective action
FF4A ERROR	Hardware error	Internal HW function test failed	<ul style="list-style-type: none"> ■ Perform reset. → See page 170, chapter 13.4. ■ Contact service if required.
FF4B WARNING	Loop error A or C	Short circuit or idle loop A or C	<ul style="list-style-type: none"> ■ Remove loop error and perform adjustment. ■ If no loop is connected, select the option "Inactive" in the menu "Detector".
FF4C WARNING	Loop error B or D	Short circuit or idle loop B or D	<ul style="list-style-type: none"> ■ Remove loop error and perform adjustment. ■ If no loop is connected, select the option "Inactive" in the menu "Detector".

Table 64: Warning and Interference Messages – Detector

Malfuncions

13.3.4 Warning and interference messages – All modules

Number	Description	Possible cause	Corrective action
6010 WARNING	Watchdog reset	SW error	Contact service if required.
8110 WARNING	Bus fault	Warning	Contact service if required.
8120 WARNING	Bus HW fault	Warning	<ul style="list-style-type: none"> ■ Check DIP switch next to service interface (position ON) ■ Remove devices at service interface if required.

Table 65: Warning and interference messages – All modules

13.4 Reset the barrier

Control unit reset is performed as follows:

- Switch of power supply and switch it on again after 10 seconds.
- or
- Press the two middle control buttons on the display for 5 seconds. → See page 107, Fig. 46.

NOTICE!



NOTICE!

Damage to the unit by too-short switching intervals of the mains voltage!

Therefore:

- To avoid damage to the equipment the power must remain shut off for at least 10 seconds.

13.5 Closing or opening the barrier arm in case of power failure

In case of power failure, the barrier arm may be in the lower or upper dead point. I.e. the barrier arm can no longer be easily moved manually. In this case, proceed as follows:

1. Remove the barrier housing hood.
2. Remove the barrier housing door.
3. Press a tool straight into the lower tool bore. The lever arm is pressed from the dead point
 - Upper tool bore for opening the barrier.
 - Lower tool bore for closing the barrier.
4. Mount the door if applicable.
5. Attach and lock the hood if applicable.

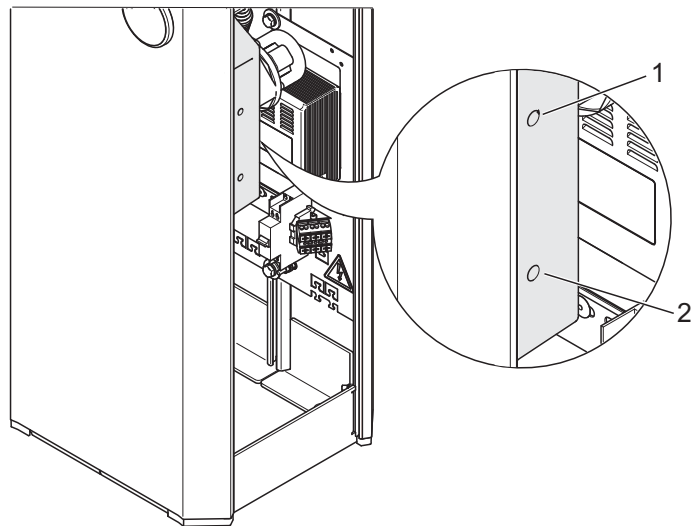

Mag00209

Fig. 56: Top and bottom tool bore

- 1 Upper tool bore for opening the barrier.
- 2 Lower tool bore for closing the barrier.



Repair

14 Repair

14.1 Safety

→ See also safety notes on page 20, chapter 2.6 "Occupational safety and special dangers".

General

 WARNING!	
	<p>WARNING! Danger by inappropriate repair!</p> <p>Inappropriate repair can cause severe or lethal injuries.</p> <p>Therefore:</p> <ul style="list-style-type: none"> – All repair work must only be performed by authorised MHTM service specialists. – Prior to work, ensure that there is sufficient assembly space. – Pay attention to tidiness and cleanliness at the assembly site! Loosely stacked or lying around components and tools are accident sources. – Only use original spare parts or spare parts approved of by MAGNETIC. Procure spare parts from your dealer or directly from the manufacturer. For the address, see invoice, delivery note or the reverse of these instructions. – After completion of repair work, ensure that all covers are correctly mounted.

Personal protective equipment

The following must be worn during all repair work:

- Work clothes
- Protective gloves
- Safety shoes
- Protective helmet.

14.2 Spare parts

⚠ WARNING!	
	<p>WARNING! Risk of injury by incorrect spare parts!</p> <p>Incorrect or defective spare parts can result in damage, malfunctions or total failure and also impair safety.</p> <p>Therefore:</p> <ul style="list-style-type: none"> – Use only the manufacturer's original spare parts.

Procure spare parts from your dealer or directly from the manufacturer. For the address, see invoice, delivery note or the reverse of these instructions.

Spare part lists can be obtained on request.

14.3 Replacing the barrier arm

Danger of injury

⚠ CAUTION!	
	<p>CAUTION! Danger of injury!</p> <p>There is a danger of injury when mounting the barrier arm.</p> <p>Therefore:</p> <ul style="list-style-type: none"> – Barrier arms as of a length of 14.8 ft (4.5 m) must be installed by two persons. We recommend also installing shorter barrier arms with two persons.

14.3.1 Barrier arm type "VarioBoom" and "MicroBoom"

Do not grease

NOTICE!	
	<p>NOTICE! Improper lubrication of components, in particular the counter bearing or flange shaft, may lead to damage of the equipment!</p> <p>Therefore:</p> <ul style="list-style-type: none"> – Do not grease the counter bearing and flange shaft.

Repair

1. Secure barrier danger area e.g. with barrier tape.
2. Remove the barrier housing hood.
3. Remove the barrier housing door.



WARNING!

Danger of crushing between barrier arm and barrier housing!

4. Switch off power supply. Ensure that the system is powered down. Secure against reactivation.
5. The barrier must be open. Open barrier arm manually if required.
6. Disassemble flange from the flange shaft together with the barrier arm. For this, loosen the 4 hexagon socket screws 10 AF at the flange.
7. Remove the flange with the barrier arm.

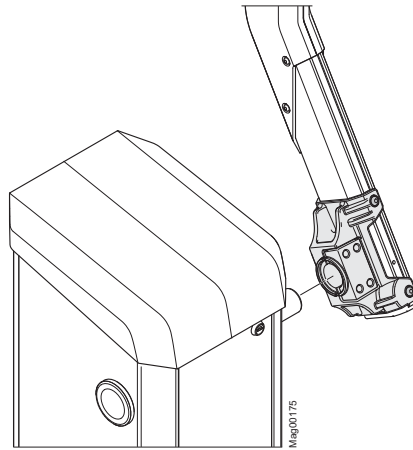

Fig. 57: Disassemble flange with barrier arm

8. Remove flange from the barrier arm. For this, loosen the 4 hexagon socket screws 5 AF at the barrier arm. Use slot nuts for the new barrier arm.

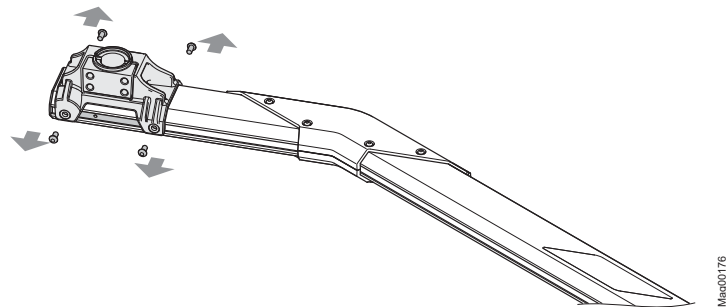
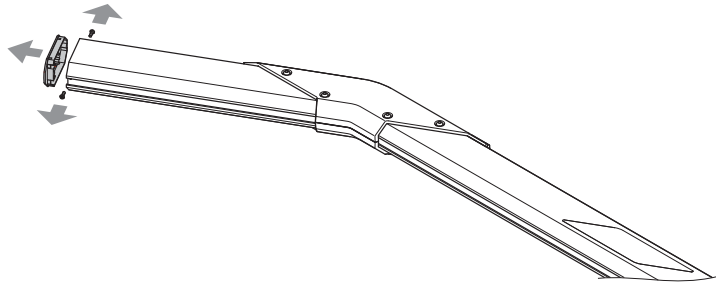

Fig. 58: Disassemble flange

9. Replacing the barrier arm.

10. Remove end cap from the barrier arm.



Mag00170

Fig. 59: Disassemble end cap

11. Slide a slot nut into the groove at the underside of the barrier arm. Place a slot nut on the upper side of the barrier arm.

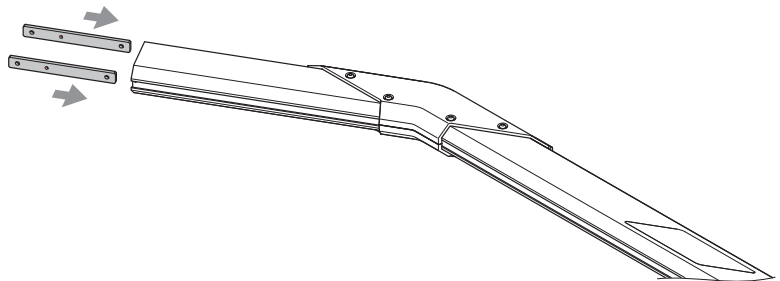

Mag00171

Fig. 60: Assemble slot nuts

12. Attach the flange with the 4 hexagon socket screw and the two slot nuts to the barrier arm. The shorter protrusion of the flange must point towards the barrier arm end. Tighten screws twice in sequence to ensure that all screws are tightened correctly.

- Use a torque wrench with hexagon socket: 5 AF
- Tightening torque: 11.801 lbf ft (16 Nm)

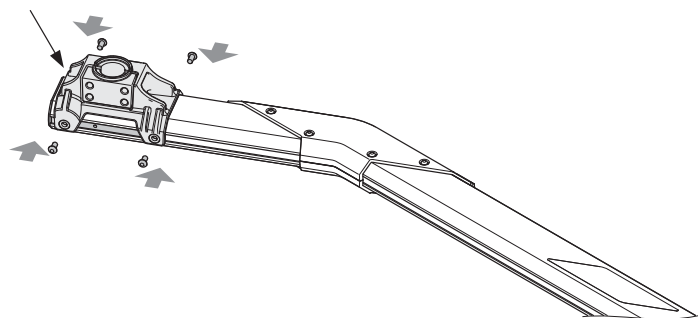

Mag00173

Fig. 61: Assembling flange

Repair

13. Install end cap to the barrier arm.

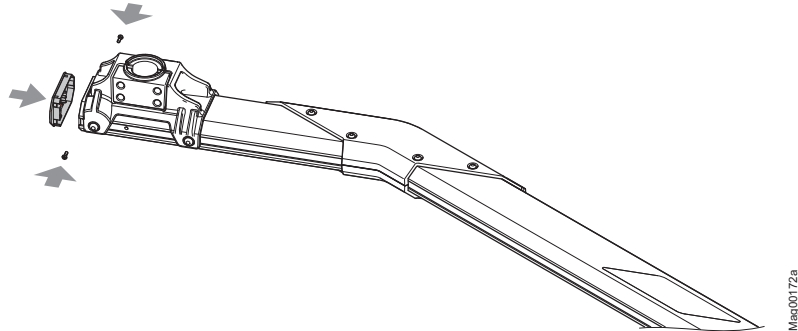



Fig. 62: Install end cap

14. Push barrier arm with pre-assembled flange onto the flange shaft.
15. Align barrier arm vertically.
16. Install the flange on the flange shaft using the 4 hexagon socket screws. To tighten the screws evenly.
- Use a torque wrench with hexagon socket: 10 AF
 - Tightening torque: 55.391 lbf ft (75 Nm)
17. Close screws and threaded bores with the included grey plastic covers.
18. Push the barrier into the top-most position. The clamping lever must be at the stop for the "open" position. If required, push straight through the upper tool bore with a tool to press the lever arm from the dead point. → See page 171, chapter 0.
19. Check the vertical alignment of the barrier arm with a level and correct with the hexagon socket screws at the flange if necessary.
20. Switch on power supply.
21. Switch the "Service" switch on the control unit. The LED lights red. The display backlighting flashes.
→ See page 123, chapter 10.7.7 Mode "Service".
22. Close the barrier with the middle right button  at the control unit.
23. Check the horizontal alignment of the barrier arm with a level and correct with the hexagon socket screws at the flange if necessary.
24. Switch the "Service" switch on the control unit. The LED must light green.
25. Switch off power supply.
26. Install the barrier housing door.
27. Attach and lock the barrier housing hood.
28. Assemble edge protection. → See page 68, chapter 8.7.

14.3.2 Barrier arm type "MicroBoom-T"

1. Secure barrier danger area e.g. with barrier tape.
2. Remove the barrier housing hood.
3. Remove the barrier housing door.



WARNING!

Danger of crushing between barrier arm and barrier housing!

4. Switch off power supply. Ensure that the system is powered down. Secure against reactivation.
5. The barrier must be open. Open barrier arm manually if required.
6. Remove barrier arm. For this, loosen the hexagon screw at the flange.

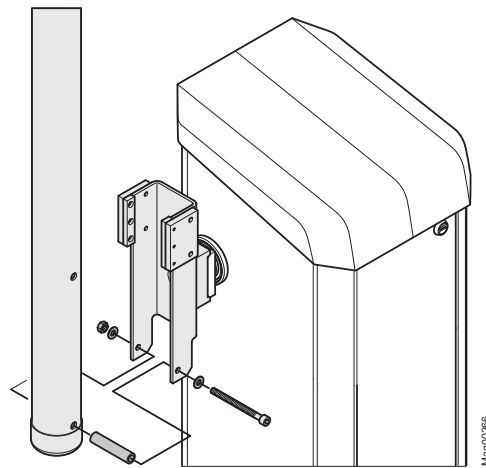



Fig. 63: Remove barrier arm

7. Replacing the barrier arm.
8. Attach the new barrier arm to the flange using the hexagon screw.
9. Push the barrier into the top-most position. The clamping lever must be at the stop for the "open" position. If required, push straight through the upper tool bore with a tool to press the lever arm from the dead point. → See page 171, chapter 13.5.
10. Check the vertical alignment of the barrier arm with a spirit level and correct with the hexagon socket screws at the flange if necessary.

Decommissioning, disassembly and disposal

11. Switch on power supply.
12. Switch the "Service" switch on the control unit. The LED lights red. The display backlighting flashes.
→ See page 123, chapter 10.7.7 Mode "Service".
13. Close the barrier with the middle right button  at the control unit.
14. Check the horizontal alignment of the barrier arm with a level and correct with the hexagon socket screws at the flange if necessary.
15. Switch the "Service" switch on the control unit. The LED must light green.
16. Switch off power supply.
17. Install the barrier housing door.
18. Attach and lock the barrier housing hood.

15 Decommissioning, disassembly and disposal

A barrier that is no longer usable should not be recycled as a complete unit, but disassembled into individual components and recycled according to material types. Non-recyclable materials have to be disposed of in an environmental-friendly manner.

- Decommissioning, disassembly and disposal of the barrier may only be carried out by specialised staff.
- Disassemble the barrier in reverse order from assembly.
- The barrier has to be disposed of in accordance with the respective country-specific regulations.



NOTE!

For expert information regarding disposal of electric equipment contact MAGNETIC or competent electricians.



FDDR7.E136510 Door, Drapery, Gate, Louver and Window Operators and Systems Certified for Canada

[Page Bottom](#)

Door, Drapery, Gate, Louver and Window Operators and Systems Certified for Canada

[See General Information for Door, Drapery, Gate, Louver and Window Operators and Systems Certified for Canada](#)

MAGNETIC AUTOCONTROL GMBH

E136510

GRIENMATT 20
79650 SCHOPFHEIM, GERMANY

For commercial and Industrial use, Gate operators, Models LS130-01, -10, -11, -41, MIB20, MIB30, MIB35, MIB40, MSE3, MSV3, MSV4, MSV5, followed by X-YYY, where "X" is R or L and "YYY" is any number 000 thru 999, MTS-8.

Models MBE30, MBE35, MBE50, followed by X-Cyyy, where "X" is R or L and yyy is 000 thru 999.

Vehicular barrier gate operators, Series ACCESS, ACCESS PRO and ACCESS SEL, may be followed by L or H, followed by L or R, followed by C, followed by three digits, may be followed by one or two digits.

Vehicular barrier gate operators, Series PARKING, PARKING PRO and PARKING SEL, may be followed by H, followed by L or R, followed by C, followed by three digits, may be followed by one or two digits.

Vehicular barrier gate operators, Series TOLL and TOLL PRO, followed by L or R, followed by C, followed by three digits, may be followed by one or two digits.

[Last Updated](#) on 2011-06-14

[Questions?](#)

[Print this page](#)

[Notice of Disclaimer](#)

[Page Top](#)

[Copyright © 2011 Underwriters Laboratories Inc.®](#)

The appearance of a company's name or product in this database does not in itself assure that products so identified have been manufactured under UL's Follow-Up Service. Only those products bearing the UL Mark should be considered to be Listed and covered under UL's Follow-Up Service. Always look for the Mark on the product.

UL permits the reproduction of the material contained in the Online Certification Directory subject to the following conditions: 1. The Guide Information, Designs and/or Listings (files) must be presented in their entirety and in a non-misleading manner, without any manipulation of the data (or drawings). 2. The statement "Reprinted from the Online Certifications Directory with permission from Underwriters Laboratories Inc." must appear adjacent to the extracted material. In addition, the reprinted material must include a copyright notice in the following format: "Copyright © 2011 Underwriters Laboratories Inc.®"

An independent organization working for a safer world with integrity, precision and knowledge.



TCB

**GRANT OF EQUIPMENT
AUTHORIZATION**

TCB

Certification

**Issued Under the Authority of the
Federal Communications Commission**

By:

**EMCC Dr. Rasek
Moggast
D-91320 Ebermannstadt,
Germany**

Date of Grant: 10/08/2003

Application Dated: 10/08/2003

**SMD-Funksteuerungs GmbH
Hans-Boeckler-Strasse 5
Rodgau, 63110
Germany**

Attention: Ulf Nordlander , Managing Director

NOT TRANSFERABLE

EQUIPMENT AUTHORIZATION is hereby issued to the named GRANTEE, and is VALID ONLY for the equipment identified hereon for use under the Commission's Rules and Regulations listed below.

FCC IDENTIFIER: QV2-SMD-53200RX
Name of Grantee: SMD-Funksteuerungs GmbH
**Equipment Class: Communications Receiver used w/Pt 15
Transmitter**
Notes: Radio Receiver Module 433 MHz AM

<u>Grant Notes</u>	<u>FCC Rule Parts</u>	<u>Frequency Range (MHZ)</u>	<u>Output Watts</u>	<u>Frequency Tolerance</u>	<u>Emission Designator</u>
CE	15B	433.92 - 433.92			

CE: This device has shown compliance with the conducted emissions limits in 15.107, 15.207, or 18.307 adopted under FCC 02-157 (ET Docket 98-80). The device may be marketed after July 11, 2005, and is not affected by the 15.37(j) or 18.123 transition provisions.



18 Appendix

18.1 Wiring diagrams

Following wiring diagrams apply to standard barriers.
Observe the customer specific wire diagrams for customer specific barriers if applicable.



Appendix

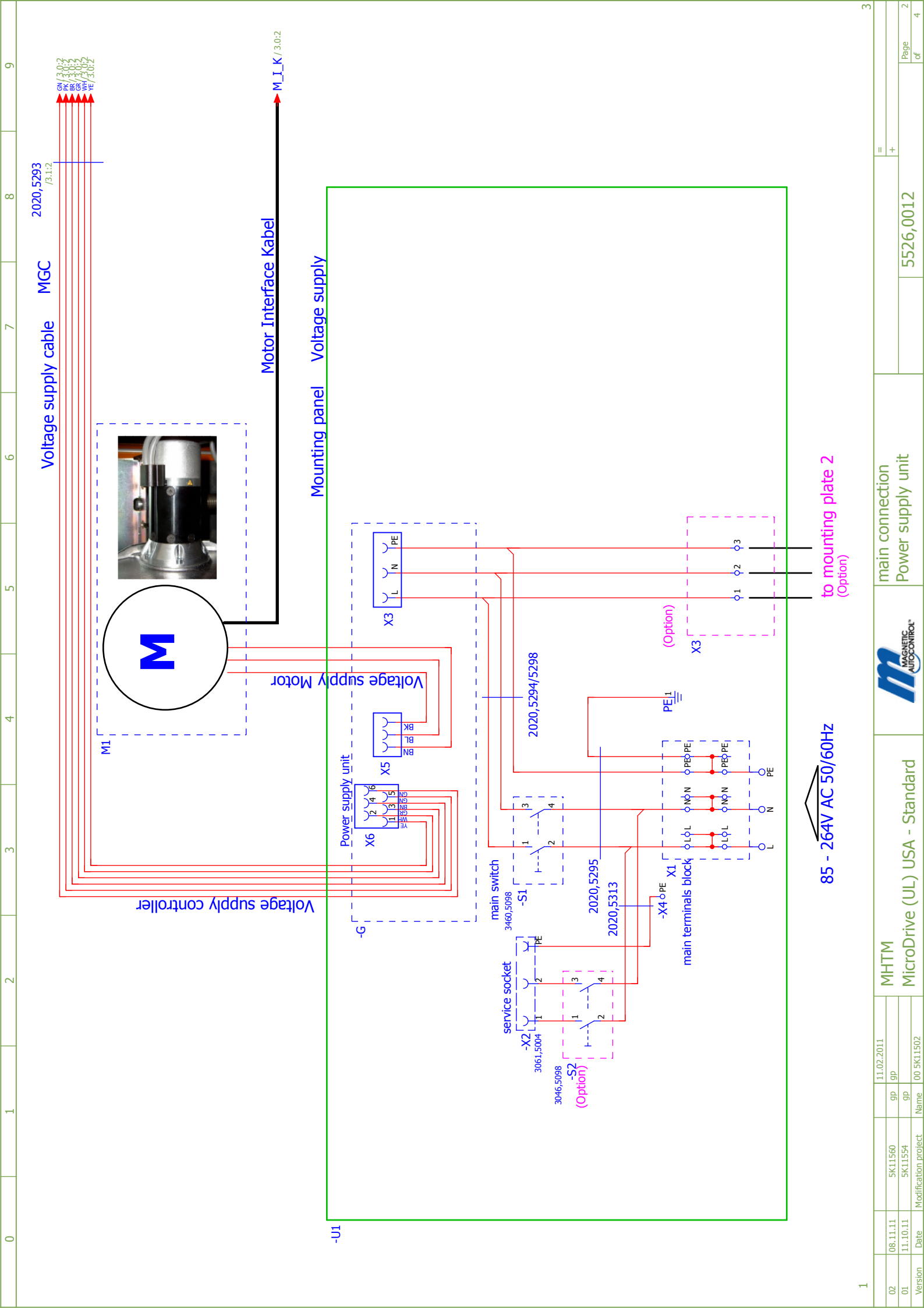

02	08.11.11	5K11560	9P	gp	11.02.2011
01	11.10.11	5K11554	9P	gp	
Version	Date	Modification project	Name		

MHTM
MicroDrive (UL) USA - Standard



main connection
Power supply unit

5526,0012

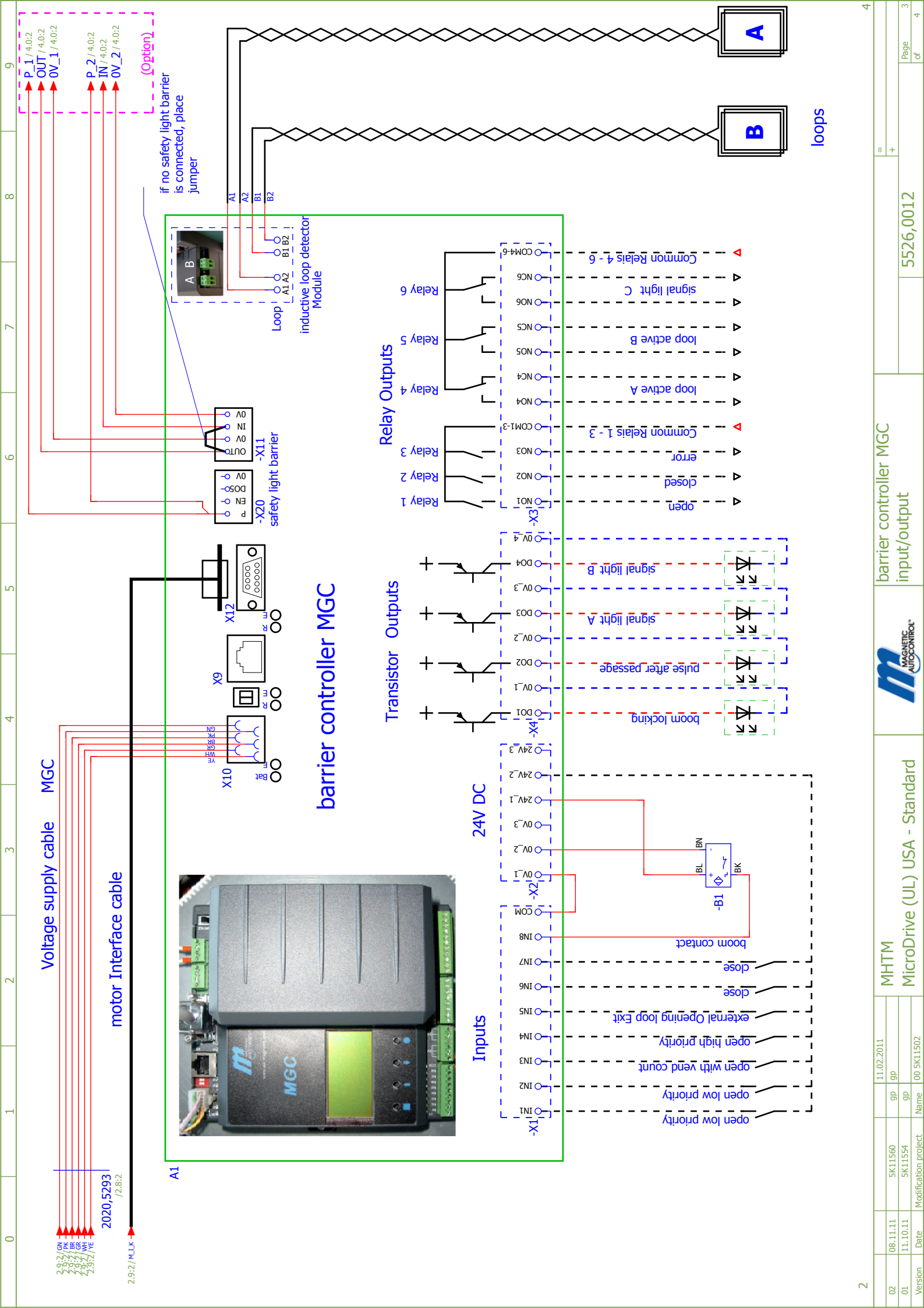

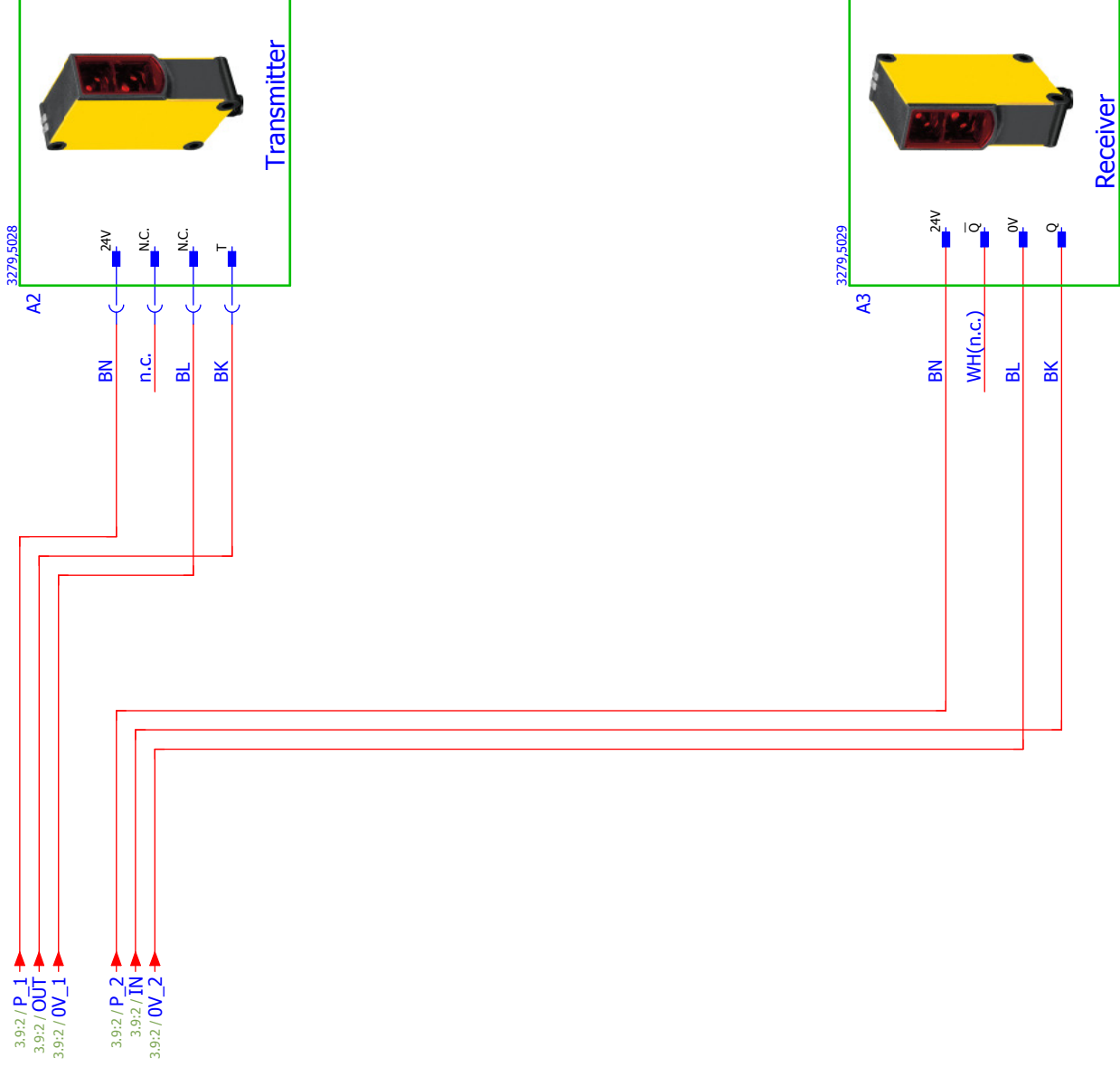

02	08.11.11	5K11560	9P	9P	11.02.2011
01	11.10.11	5K11554	9P	9P	
Version	Date	Modification project	Name	Name	

MHTM
MicroDrive (UL) USA - Standard



safety-light barriers [Option]

5526,0012

18.2 Menu setup

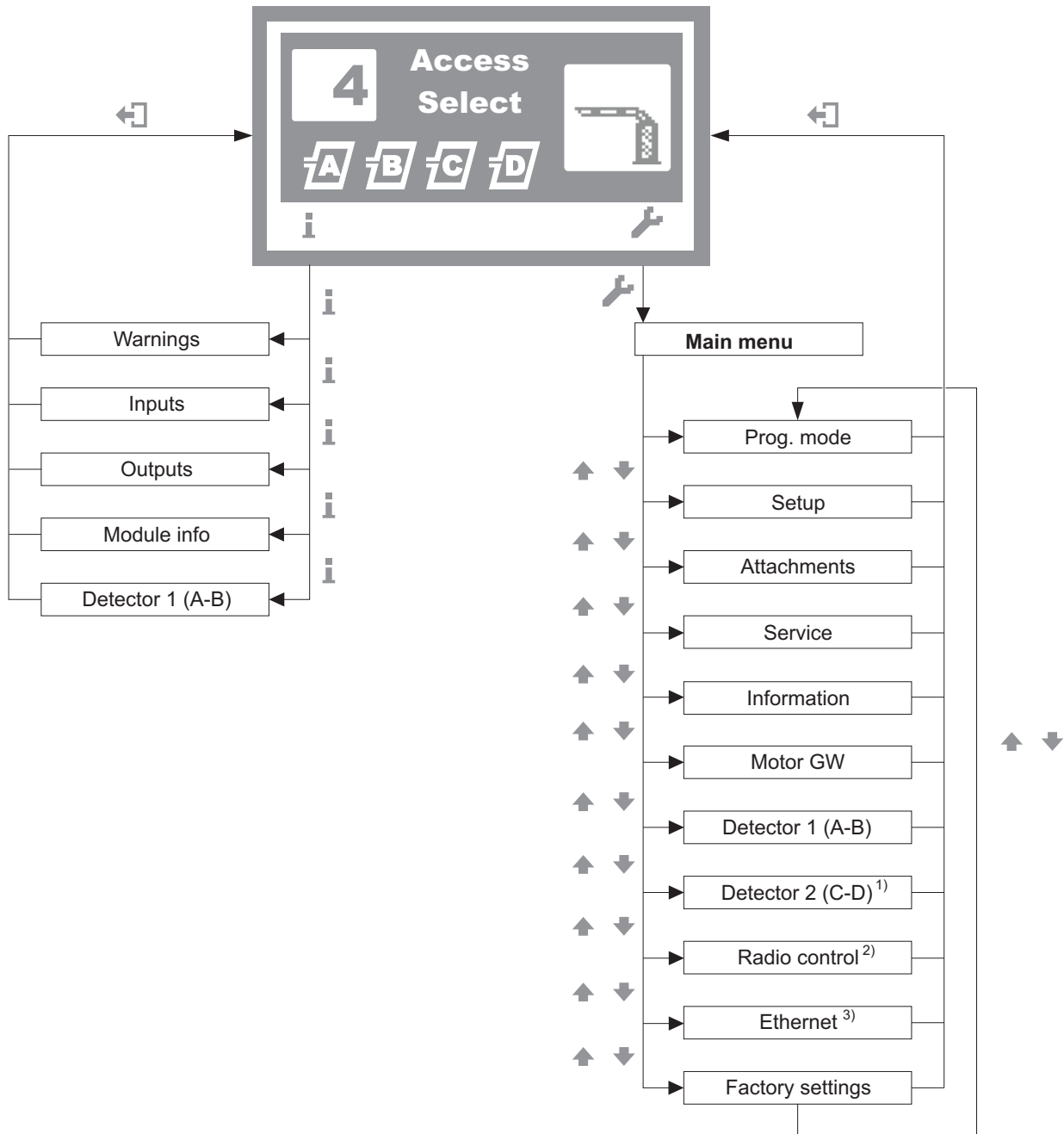

Mag00256a

Fig. 64: Menu "Main menu" and "Information"

- 1 Menu "Detector 2 (C-D)" with second "Detector" plug-in module only (optional)
- 2 Menu "Radio control" with optional "Radio" plug-in module only
- 3 Menu "Ethernet" with optional "Ethernet" plug-in module only

Appendix

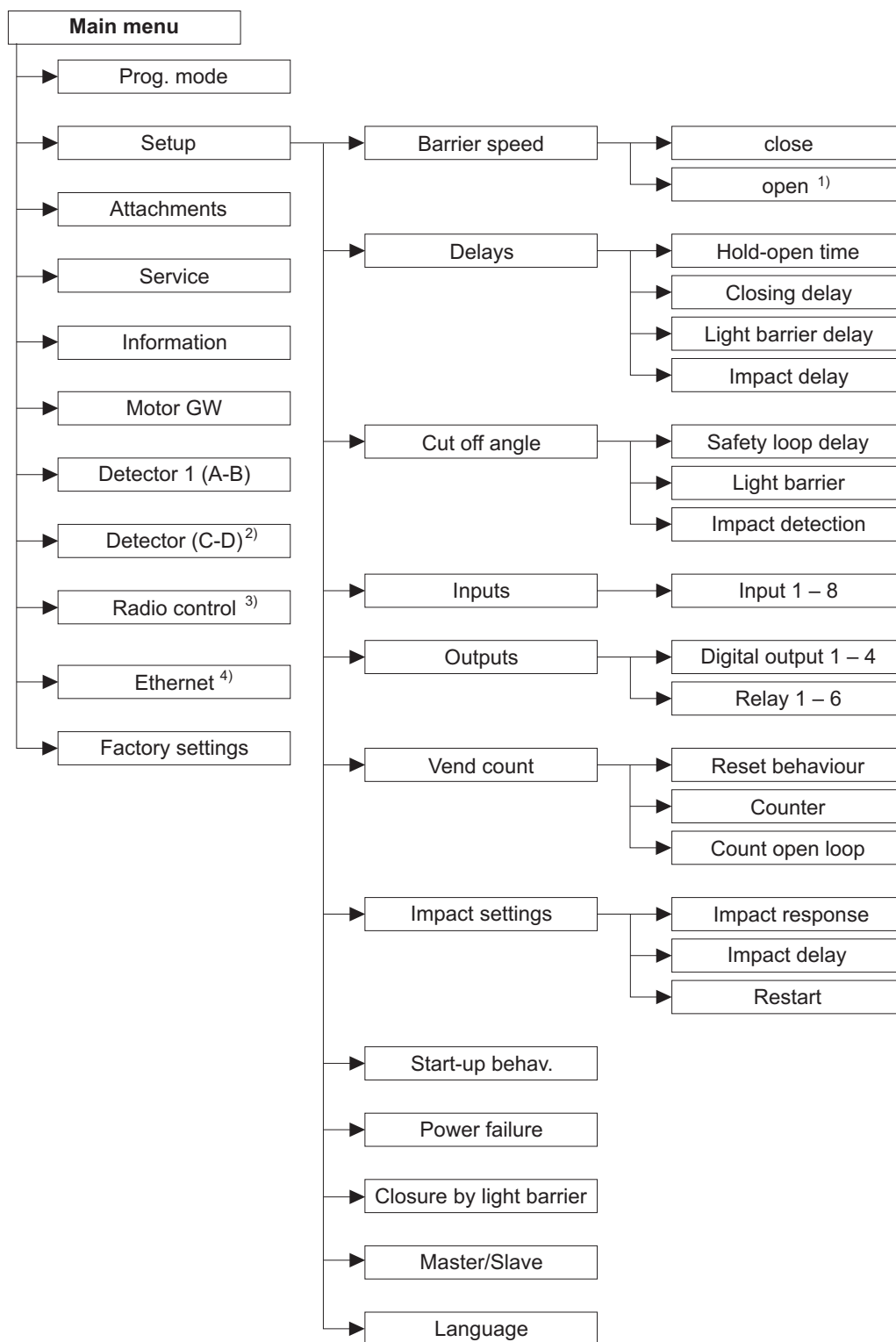

Mag00130g

Fig. 65: Menu "Main menu"

- 1 The parameter is displayed for the following boom types: Access Pro, Access Pro L, Access Pro H, Access Select and Access Select L, Parking Pro and Parking Select.
- 2 Menu "Detector 2 (C-D)" with second "Detector" plug-in module only (optional)
- 3 Menu "Radio control" with optional "Radio" plug-in module only
- 4 Menu "Ethernet" with optional "Ethernet" plug-in module only

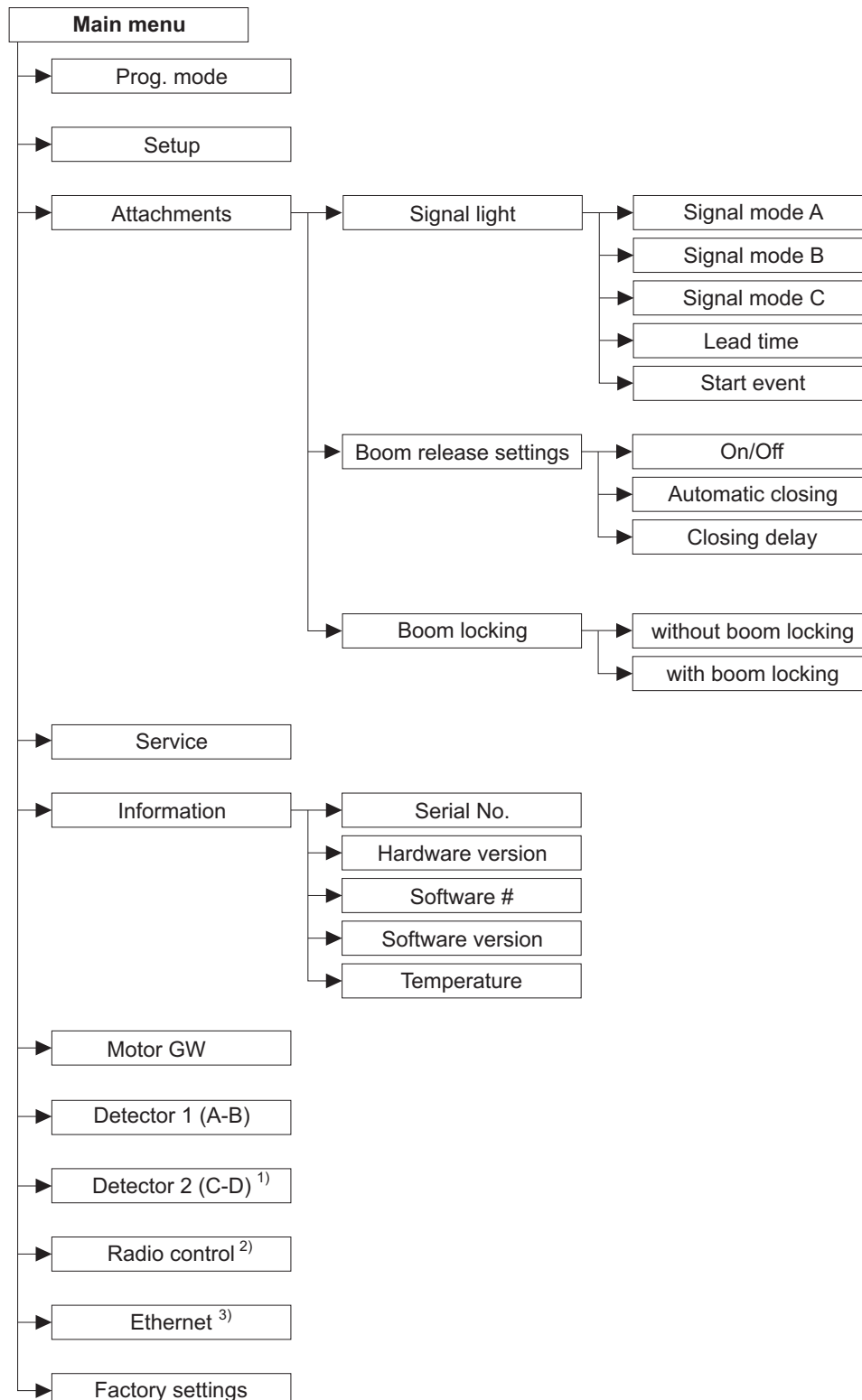

Mag00131d

Fig. 66: Menu "Main menu" – Sub menus "Attachments" and "Information"

- 1 Menu "Detector 2 (C-D)" with second "Detector" plug-in module only (optional)
- 2 Menu "Radio control" with optional "Radio" plug-in module only
- 3 Menu "Ethernet" with optional "Ethernet" plug-in module only

Appendix

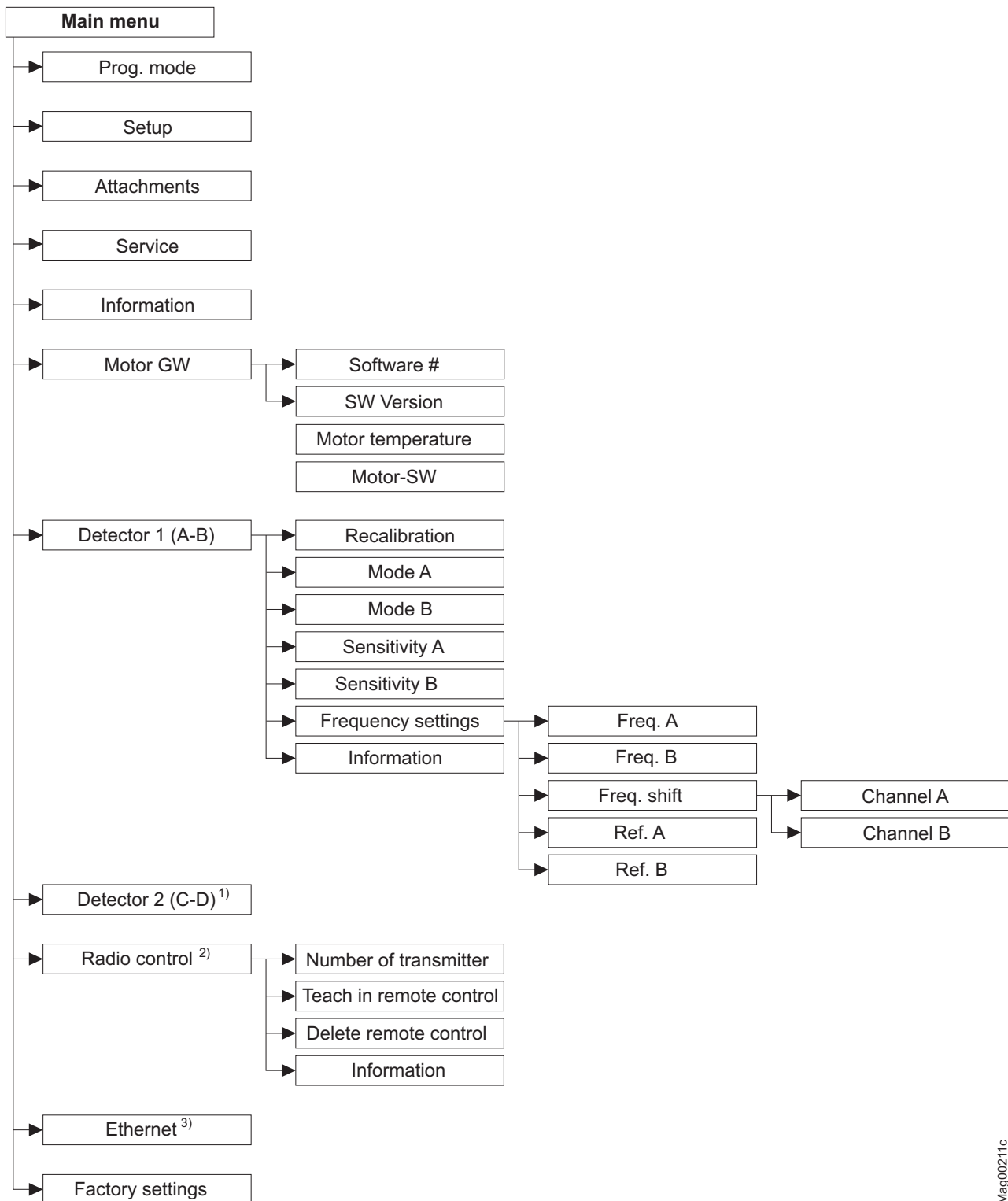

Mag00211c

Fig. 67: Menu "Main menu" – Sub menus "Motor GW", "Detector 1 (A–B)" and "Radio control"

- 1 Menu "Detector 2 (C-D)" with second "Detector" plug-in module only (optional)
- 2 Menu "Radio control" with optional "Radio" plug-in module only
- 3 Menu "Ethernet" with optional "Ethernet" plug-in module only

Index

A	
Assemble housing	66
Assembly	
Housing	66
Safety light barrier	69
Assembly and installation	
Required steps	55
Assembly site	57
Light barrier posts	59
B	
Balancing springs	82
Check	81
Setting	81
Barrier arm	43, 44, 45
Barrier housing	43, 44, 45
Bistable	116
C	
Change value	107
Changes	18
Check	
Assembly	87
Before to initial start-up	155
Electrical connection	105
Installation	87
Check assembly	87
Check installation	87
Cleaning	159
Commissioning	155
Connecting mains supply	91
Control buttons	
Function	108
Control elements	106
Control unit	
Displays	107
Technical data	41
Control unit control elements	106
Copyright	13
Customer service	14
D	
Danger area	28
Deadman	115
Decommissioning	178
Temporarily	157
Design	43
Digital inputs	98
Digital outputs	101
Dimensions	
Access	31
Access Pro H	34
Parking	37
Toll	39
Disassembly	178
Display	
Symbols	108
Disposal	178
E	
Electrical connection	88
Electrical specialists	19
Empty conduit	
Light barrier	59, 60
Empty conduits	57, 58
Environmental protection	15
F	
Foundation	43, 44, 45, 57, 58
Light barrier post	60
Light barrier posts	59
Foundation plan	58, 60
Function	46
G	
General	11
Grant of equipment authorization	181
H	
Hazard Notes	21
I	
Identification	29
Induction loops	61, 64, 65
Inspection	
During the first start-up	155
Instructed People	19
Intended use	16
L	
Limitation of liability	13
Loop detector plug-in module	
Technical data	42
Lorry loops	51
Lorry/passenger car loops	52
M	
Maintained contact	114
Maintenance	158
Maintenance schedule	160
Malfunction Table	163
Malfunctions	162

Index

Master	138	Transport	47
MHTM™ MicroDrive service expert	19	Safety devices	
Modifications	18	Plausibility check	95
Mounting material		Safety Instructions	3
Requirements	66, 68	Safety light barrier	69
O		Scope of delivery	14
Occupational safety	20, 21	Select program mode	113
Open/Closed button	117	Service switch	123
Operating Instructions	11	Setup	
Operating Personnel		Program mode	113
Requirements	19	Slave	138
Operational view	107	Spare parts	173
Output relay	101	Specialised Staff	19
P		Specialists	
Parallel operation	138	Requirements	19
Parameterising		Storage	49
Options	111	Switching off	156
Values	112	Switching on	156
Passenger car loops	50, 51	Symbols	
Pendulum support	43, 44	Control button functions	108
Personal protective equipment	20	Current program mode	110
Pictogram explanation	12	Current state of the barrier	109
Program mode		Current state of the induction loops	110
Deadman	115	Further	110
Maintained contact	114	T	
Pulse control	116	Technical data	31
Two-Pulse control	117	Transport	49
Pulse control	116	Transport inspection	48
R		Two-Pulse control	117
Radio plug-in module		Type code	30
Technical data	42	Type plate	29
Reinforcement	57, 58	U	
Reset barrier	170	UL-Declaration	14
S		Unpacking	66
Safety	16	V	
Commissioning	154	VarioBoom	43
Electrical connection	88	W	
Maintenance	158	Warning notes	12
Malfunctions	162	Warning signs	87
Operation	154	Warranty	14
Repair	172		

MAGNETIC Automation Corporation
3160 Murrell Road
Rockledge, Florida, 32955
USA

Address sales partner:

Tel.: +1 321 635 8585
Fax.: +1 321 635 9449
E-Mail: info@ac-magnetic.com
Internet: www.ac-magnetic.com



F05475758