

# Toll

## Toll barrier



### For rapid toll processing

Rapid, reliable, and economical processing of road users is essential when collecting toll charges at bridges, tunnels and on roads. Toll barriers from Magnetic have been specially designed for this situation. The innovative MHTM™ drive at the heart of the barriers is characterised by its speed, lack of maintenance and energy efficiency, and thus keeps long-term costs down. The Toll barriers can be adapted to meet individual requirements: there are four models with opening times of from

1.3–0.3 s, which can be equipped with a variety of control devices, flanges and barrier booms. All barrier boom types can be provided with swing-away flange. In the case of a collision with a vehicle, the barrier boom is released and can be manually re-engaged afterwards. This protects the barrier boom and the drive unit. There is also the optional auto-swing-away flange for the soft boom, which automatically re-engages after a collision with a vehicle.

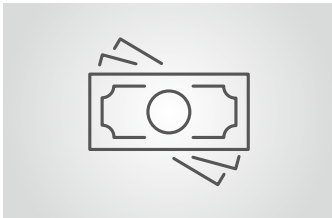

### Effective toll processing

Toll barriers from Magnetic are the optimum solution for all toll applications thanks to their speed, reliability and low operating costs.



### Innovative drive technology

The MHTM™ drive unit operates without maintenance, energy-efficiently and quietly. Its high torque ensures best possible operation even under extreme weather conditions.

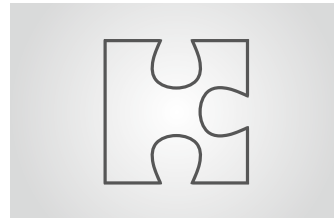

### Individual configuration

Four models, three control units, three different barrier booms – the Toll barriers can be individually adapted to your requirements. Our staff would be pleased to advise you!



### Easy access to components

Two simple hand movements suffice: easy access to the control system and drive unit by removing the hood and front panel. This increases user-friendliness and speeds up commissioning and servicing.

ACCESS

PARKING

TOLL

TRAFFIC

# Toll

## Toll barrier

- > Opening and closing times down to 0.3 s
- > Very low operating costs thanks to efficient and long-lived MHTM™ drive
- > Ease-of-use and optimum accessibility thanks to well thought-out design
- > Prizewinning design: German Design Award 2014 and red dot design award 2012
- > Designed for 10 million opening and closing cycles



Technical Data	Toll	Toll Pro	Toll HighSpeed	Toll HighSpeed 2
Lane width	Max. 3.0 m	Max. 3.0 m	Max. 3.0 m	Max. 3.2 m (with 2 barriers)
Opening/closing time	1.3 s	0.9 s	0.6 s	0.3 s
Power consumption	Max. 55 W	Max. 95 W	Max. 320 W	Max. 450 W
Drive technology	MHTM™	MHTM™	MHTM™	MHTM™
Voltage	100–240 V AC, 50–60 Hz	100–240 V AC, 50–60 Hz	100–240 V AC, 50–60 Hz	100–240 V AC, 50–60 Hz
Duty cycle	100 %	100 %	100 %	100 %
Housing dimensions (W x D x H)	315 x 360 x 1115 mm	315 x 360 x 1115 mm	315 x 360 x 1115 mm	315 x 360 x 1115 mm
Enclosure rating	IP54	IP54	IP54	IP54
Temperature range	-30 to +55 °C	-30 to +55 °C	-30 to +55 °C	-30 to +55 °C
Weight	Approx. 42 kg	Approx. 42 kg	Approx. 44 kg	Approx. 44 kg

Features	Toll	Toll Pro	Toll HighSpeed	Toll HighSpeed 2
Standard colour	RAL 2000	RAL 2000	RAL 2000	RAL 2000
Barrier boom	3 models available	3 models available	3 models available	2 models available
Control system	3 models available	3 models available	2 models available	2 models available
Number of digital inputs	8	8	8	8
Input with test for safety light barrier/laser scanner	1	1	1	1
Number of relay/digital outputs	6/4	6/4	6/4	6/4
Closing speed	Adjustable	Adjustable	Adjustable	Adjustable

Control systems	MGC without loop detector	MGC with loop detector	MGC Pro
2 detector channels		✓	✓
Adjustable inputs/outputs			✓
3 opening speeds			✓

Options	Toll	Toll Pro	Toll HighSpeed	Toll HighSpeed2
Special colours	✓	✓	✓	✓
Round boom (MicroBoom-T)	Up to 3.0 m	Up to 3.0 m	Up to 3.0 m	Up to 1.5 m
Octagonal boom (MicroBoom-S)	Up to 3.5 m	Up to 2.5 m	Up to 2.5 m	
Soft boom (MicroBoom-AT)	Up to 3.0 m	Up to 3.0 m	Up to 3.0 m	Up to 1.5 m
Swing-away flange	All booms	All booms	All booms	All booms
Auto-swing-away flange	Only soft boom	Only soft boom	Only soft boom	Only soft boom
Boom drop contact	✓	✓	✓	✓
Hood light	✓	✓	✓	✓
Key-operated switch	✓	✓	✓	✓
Radio module	✓	✓	✓	✓
Ethernet module	✓	✓	✓	✓
RS485 module	✓	✓	✓	✓
CAN module (counting)	✓	✓	✓	✓
Second detector module	✓	✓	✓	✓
GSM module	✓	✓	✓	✓
Safety light barrier/laser scanner	✓	✓	✓	✓
Battery backup	✓	✓		

## Dimensional drawings

Toll with round boom (MicroBoom-T)

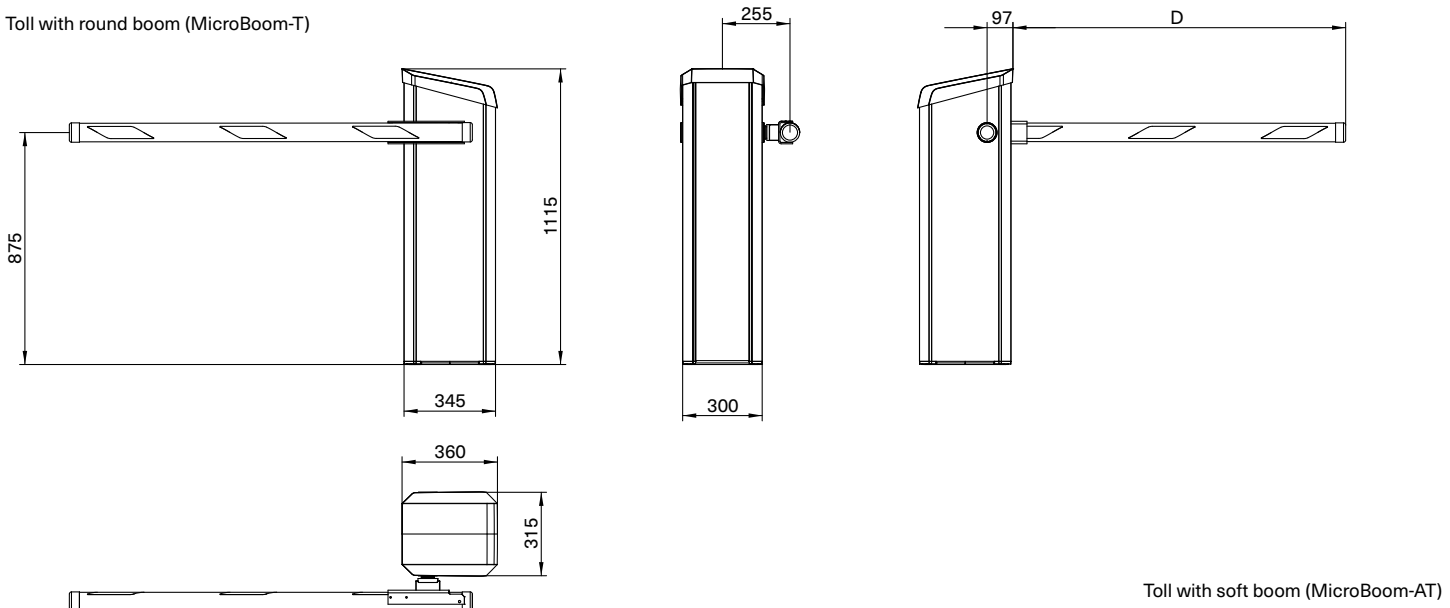

Toll with soft boom (MicroBoom-AT)

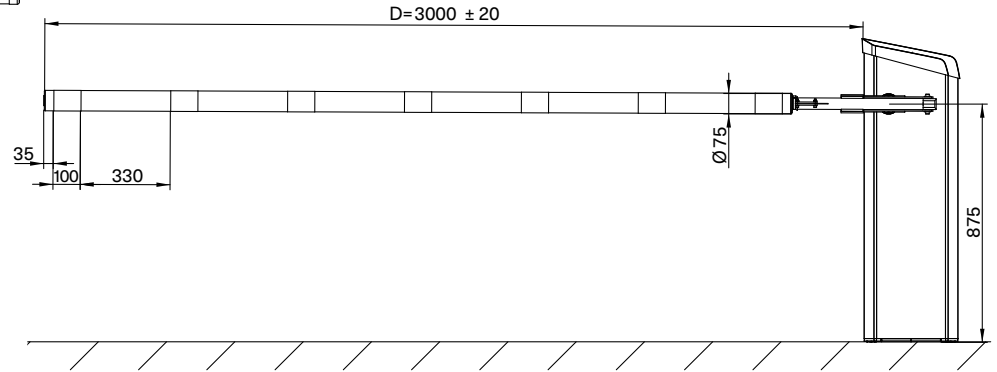

The dimensions of the housings are identical for all models.

# Access to Progress

Magnetic stands for pioneering products – in every way. Our access control systems for vehicles or pedestrians clear the way for thousands of people every day – at car parks, toll gates, stations, airports and in buildings. Our technology is also pioneering, however: with innovative drives, intelligent control systems and well thought-out details it provides maximum safety and longevity. Are you also on the path to Magnetic?



## Vehicle barriers

- Access barriers
- Parking barriers
- Toll barriers
- Special barriers



## Pedestrian gates

- Turnstiles
- Swing gates
- Tripod gates
- Retractable gates
- Wing gates



## Terminals

- Cars
- Trucks