

Accessories for the barrier boom

Boom locking set (BV01 / BV50 / BV51)

The boom locking set BV, comprising a support post, locking unit, electrical components and supply unit, offers best protection against forced opening of the barrier boom.

The complete unit and cables are installed in the barrier boom and are led into the barrier housing. This ensures best protection against corrosion, manipulation and vandalism.

In a closed state, current flows through the boom locking. The quantity of heat of the solenoid prevents condensation and corrosion, thus ensuring reliable operation particularly in wintery conditions.

In case of a power failure, the boom locking opens automatically and the barrier boom can be opened manually.

The boom locking set **BV01** is used with all Magnetic.Access barriers except for Magnetic.Access XL and Magnetic.Access XXL models.

For Magnetic.Access XL / XXL barriers with a lane width greater than 20 ft, the boom locking set **BV50** is required. The boom locking set **BV51** is required for Magnetic.Access XL and Magnetic.Access XXL barriers with lane widths up to 20 ft. The BV51 includes a special support post with a bigger support fork to accept the boom profile used for lane widths up to 20 ft.

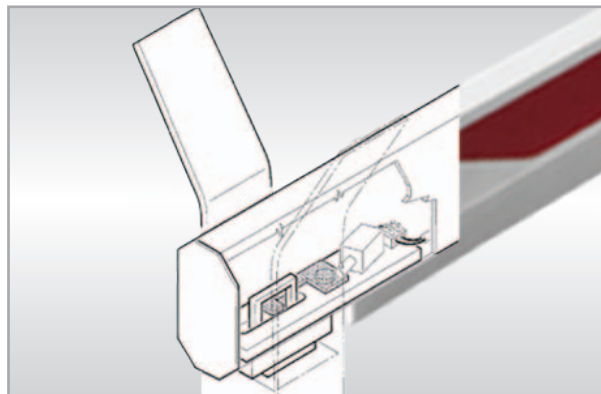

Supported barrier types

Magnetic.Access	all
Magnetic.Parking	all